

# Phoenix xf

## Product Manual

**© Copyright HS Europe Limited 2009**

All rights reserved. No part of this document may be stored in a retrieval system, or transmitted in any form or by any means to persons not employed by Heatstar without written permission of HS Europe Limited.

Although every effort has been taken to ensure the accuracy of this document it may be necessary, without notice, to make amendments or correct omissions. HS Europe Limited cannot accept responsibility for damage, injury, or expenses resulting there from.

Printed in the UK

---

## IMPORTANT

This product has been thoroughly tested before leaving the Heatstar factory.

However, please check at the earliest opportunity that the product has arrived in good condition and that no transport damage is apparent. If any damage is suspected, please contact the suppliers / carriers immediately.

The product **MUST** be protected from the elements and not exposed to temperatures below freezing during transport or storage.

Please take the time to read this manual thoroughly before commencing installation.

If there are any questions then please contact *Heatstar Customer Support* :

*Tel : 00 44 1983 521 465*  
*Fax : 00 44 1983 822 016*  
*E-Mail : info@heatstar.com*

## WARNING

Only suitably qualified personnel who thoroughly understand the operation of this product and any associated machinery should install, start-up or attempt maintenance of this product. Non-compliance with this warning may result in personal injury and / or equipment damage.

Never work on any control equipment without first isolating all electrical power supplies from the equipment.

The product must be connected to an appropriate electrical safety earth. Failure to do so represents an electrical shock hazard.

## INTENDED USERS

This manual is to be made available to all persons who are required to install, operate or service the product or any other associated operation. Please ensure that a copy of this manual is presented to the end customer. Additional copies of this manual are available on request.

# WARRANTY

HS EUROPE LIMITED warrants the Heatstar product against defects in materials and workmanship for a period of twelve months from the date of delivery on the terms detailed in HS EUROPE Limited Conditions of Sale.

During that period, HS EUROPE LIMITED will remedy all such defects within the UK without charge for parts or labour, upon proof of purchase within the warranty period. Warranty provision for product sales and installations outside the UK will be by prior agreement only.

This warranty does not extend to damage resulting from improper installation, misuse, neglect or damage.

In no event shall HS EUROPE LIMITED be liable for incidental or consequential damages.

## **NO CLAIMS WILL BE ACCEPTED IF :-**

The Heatstar product is in any way incorrectly applied for the application in terms of performance capacity or suitability.

The Heatstar product is installed in any way that is not in accordance with current procedures as defined by HS EUROPE LIMITED from time to time and documented in the installation manual.

The Heatstar product has been worked upon or adjusted by anyone other than a person authorised to do so, in writing, by HS EUROPE LIMITED (external control panel settings excluded).

The air flow to and from the Heatstar product is more than 20% higher or lower than the indicated rating.

The Low Temperature Hot Water (L.T.H.W) supply to the Heatstar product fails to meet the indicated rating.

The pool water flow through the Heatstar product is more than 20% higher or lower than the indicated rating.

The Heatstar product has been exposed to swimming pool water with a condition out side of the following limits :

pH level	between 7.2 and 7.8.
Total Alkalinity	between 80 and 160 ppm
Free chlorine	between 1.0 and 3.0 ppm
Bromine	between 2.0 and 3.0 ppm
Ozone	between 0.8 and 1.0 ppm
Baquacil	between 25 and 50
T.D.S.	less than 1500 ppm

Any electrolytic or salt based water purification systems have been used on the pool.

Any chemical dosing method, whether in tablet form or otherwise, has been introduced upstream of the Heatstar product within the pool water filtration circuit.

Any form of corrosion damage within the Heatstar product is found to be present.

The Heatstar product has suffered damage through the freezing of water inside.

The electrical supply to the Heatstar product is incorrect and outside of the specification rating required for the product.

The term 'indicated rating' relates to the data contained within the 'Installation Services' document supplied with the product, copy available on request.

Please note that the manufacturers warranty runs from the DATE OF DELIVERY and not from when the system is installed or commissioned.

**YOUR STATUTORY RIGHTS ARE NOT AFFECTED.**

Extended warranty cover can be obtained for the Heatstar product after the initial period for an additional premium, see 'Extended Warrantees'.

# HOW TO USE THIS MANUAL

This manual provides information to support the installation and operation of the Heatstar swimming pool environmental control product. The manual is divided into sections covering the various aspects of the installation and operation procedure. The following index is given to assist in locating and using the information contained within the manual :

## **INFORMATION :**

---

WARRANTY REGISTRATION . . . . .	4
ENVIRONMENTAL CONTROL REQUIREMENTS . . . . .	5
PRODUCT OVERVIEW . . . . .	7
PRINCIPLE OF OPERATION . . . . .	9

## **INSTALLATION :**

---

INSTALLATION REQUIREMENT SUMMARY . . . . .	10
APPLICATION NOTES . . . . .	11
OFF LOADING AND MANOEUVRING THE PRODUCT . . . . .	11
PLANT ROOM LAYOUT . . . . .	11
MINIMUM MAINTENANCE ACCESS . . . . .	12
POSITIONING THE PRODUCT . . . . .	13
AIR DISTRIBUTION DUCT SYSTEM . . . . .	13
POOL WATER PIPE CONNECTIONS . . . . .	17
FUEL BOILER SYSTEM PIPE CONNECTIONS . . . . .	20
ELECTRICAL CONNECTIONS . . . . .	24
CONDENSATE WATER DRAINAGE . . . . .	33

## **OPERATION :**

---

PRINCIPLE OF CONTROL . . . . .	34
ABOUT THE CONTROLS . . . . .	35
ABOUT THE HEATSTAR CONTROL PANEL . . . . .	37
INITIAL CONTROL SETTINGS . . . . .	39
STARTING THE HEATSTAR . . . . .	40
COMMISSIONING THE INSTALLATION . . . . .	41
ABOUT THE WARMING UP PERIOD . . . . .	43
ADJUSTMENTS TO THE CONTROLS . . . . .	44
CONTROL OF THE POOL WATER CIRCULATING PUMP . . . . .	44
CONTROL OF THE FUEL BOILER . . . . .	44

## **MAINTANENCE :**

---

MAINTENANCE REQUIREMENT . . . . .	45
FROST DAMAGE PREVENTION . . . . .	46
CORROSION DAMAGE PREVENTION . . . . .	47
FAULT FINDING . . . . .	49
EXTENDED WARRANTEES. . . . .	54
EC DECLARATION OF CONFORMITY . . . . .	55

# WARRANTY REGISTRATION

To ensure that the correct warranty is given and to enhance response and efficiency should a service call prove necessary under the manufacturers warranty, the 'Warranty Registration Form' should be completed and returned to Heatstar as soon as possible.

The information contained will definitely NOT be forwarded to any third party and your statutory rights are not affected.

NAME : \_\_\_\_\_

ADDRESS : \_\_\_\_\_

\_\_\_\_\_

\_\_\_\_\_

POST CODE : \_\_\_\_\_

DAY TIME TEL. No. : \_\_\_\_\_

EQUIPMENT MODEL : \_\_\_\_\_ (If known).

SERIAL No. : \_\_\_\_\_ (If known).

NAME OF SUPPLIER : \_\_\_\_\_

Do you wish to receive details relating to routine maintenance of the equipment at this time (See 'maintenance')

YES / NO

SEND TO : HS EUROPE LIMITED  
Dodnor Park, Newport, Isle Of Wight, England, UK. PO30 5XB

Heatstar would be pleased to provide a stamped, addressed envelope on request.

Thank you for your assistance.

# ENVIRONMENTAL CONTROL REQUIREMENTS :

## **POOL WATER TEMPERATURE :**

The pool water requires to be heated to an acceptable temperature. Within a typical indoor pool, the pool water is normally heated to a temperature between 26°C and 31°C. The vast majority of the heat loss from the pool water is through evaporation from the pool surface into the pool hall air.

## **POOL HALL AIR TEMPERATURE :**

The pool hall air requires to be heated to an acceptable temperature.

Ideally, in order to limit heat loss and evaporation from the pool water surface, the pool hall air temperature should be maintained slightly higher than that of the pool water. For example, if the pool water temperature is 28°C, the pool hall air temperature should be maintained at 30°C.

It should be noted that, although such high air temperatures provide a pleasant environment for suitably attired bathers, for whom wetted skin enhances the chilling effect on the body, such conditions may prove uncomfortably warm for other activities and for fully clothed spectators.

## **POOL HALL HUMIDITY :**

The water evaporated from the pool surface is present in the pool hall air in the form of humidity.

This moisture laden humid air also contains the majority of the heat lost from the pool water and therefore is rich in energy. This energy is referred to as latent heat.

The amount of humidity is expressed as % Relative Humidity (% R.H.). The amount of moisture which the air can hold before condensation starts to occur is 'relative' to the temperature of the air.

Therefore, it is possible to increase the 'relative humidity' simply by reducing the air temperature, although the actual quantity of moisture in the air would remain unaltered. Likewise, a decrease in 'relative humidity' can be achieved simply by increasing the air temperature.

The cooler the air, the higher the 'relative humidity' reading and the easier condensation will occur.

## **WHAT IS THE IDEAL HUMIDITY LEVEL?**

Within a typical indoor pool, the humidity would be controlled at around 60-65% R.H., which would provide pleasant conditions for bathers and minimal condensation on the pool hall structure. If the relative humidity is reduced further, then the rate of evaporation, and therefore the heat loss, from the pool water is unnecessarily increased together with the requirement for dehumidification.

## **HOW IS THE HUMIDITY LEVEL CONTROLLED?**

If the pool humidity level is not limited, then heavy condensation will occur on the pool hall building structure, leading to rapid deterioration of the decor and possible eventual structural failure.

To prevent this, a method of 'dehumidification' must be employed.

In the past fuel costs were comparatively cheap and, therefore, it was possible to simply extract the humid energy laden pool air to out side, whilst replacing it with cooler fresh air, which required rapid heating to an acceptable temperature.

Given present day fuel costs, such a wasteful approach would, understandably, prove prohibitively expensive to operate.

## **HOW DOES A 'POOL WATER SURFACE COVER' WORK ?**

Savings on operating costs are often possible through the use of a pool surface cover.

Such a cover primarily acts to 'seal off' the pool water surface when the pool is not in use, reducing evaporation and heat loss to an absolute minimum.

When a pool surface cover is in place, the pool hall air can then be allowed to fall to a temperature below that of the pool water without any adverse effects. This is referred to as the 'set back air temperature'.

Prior to the pool cover being removed, the pool hall air temperature should ideally first be restored to the normal level i.e. above that of the pool water.

A pool cover can provide the following energy saving benefits :

- When a pool surface cover is in place, the heat loss through convection and evaporation from the pool water is reduced and, as a result, less pool water heating is necessary.
- As the pool air can be maintained at a lower temperature when a pool cover is in place, less air heating is necessary.
- In reducing evaporation from the pool surface, the amount of dehumidification necessary is also reduced.

Please note that liquid evaporation inhibitors, although beneficial, will not offer the benefits of a physical pool cover.

## **FACTORS AFFECTING HEAT LOSS & HUMIDITY :**

The following factors affect the rate of evaporation and heat loss from the pool water surface and subsequently the humidity within the pool hall air :

- Surface area of the pool and other water features.
- Pool water temperature in relation to the pool hall air temperature.
- Swimming activity within the pool.
- Wetted pool surround resulting from swimming activity.
- Humidity level of the pool hall air.
- Air movement across the pool water surface.
- Use of a pool water surface cover.

The following factors affect the rate of heat loss from the pool hall air :

- Structural / fabric heat loss from the pool hall walls, roof, windows etc.
- Amount of colder outside fresh air introduced to the pool hall.

## **FRESH AIR REQUIREMENTS :**

The majority of modern heat recovery systems primarily 're-circulate' the pool hall air. The amount of fresh air which is required to be deliberately introduced varies depending upon the nature of the application:

A small lightly used domestic pool fitted with a pool surface cover will require only minimal fresh air introduction. A large commercial pool with high levels of usage will require a much higher rate of fresh air introduction.

# PRODUCT OVERVIEW

## **PURPOSE :**

The Heatstar is a product which is intended to be used, in association with other equipment and services, to facilitate control of the environment within an indoor swimming pool.

The term 'environmental control', in this instance, relates to temperatures, humidity levels and ventilation provision.

## **MAJOR COMPONENTS :**

The Heatstar incorporates the following major components :

- A main supply fan to take air to and from the pool hall.
- An air extraction fan to ventilate pool hall air to out side.
- Air mixing louvres to control the amount of fresh air brought in.
- A plate heat recuperator to reclaim heat from air ventilated to outside.

## **MODEL VARIATIONS :**

To confirm your exact model, view the data plate on the Heatstar product.

### **'Super' Versions :**

The term 'Super' in the model name means that the Heatstar product incorporates an integral air heating coil to provide the main pool hall air heating.

### **'Super Plus' Versions :**

The term 'Super Plus' in the model name means that the Heatstar product Incorporates an integral air heating coil, to provide the main pool hall air heating, plus a pool water heating pack, to also provide the main pool water heating.

### **'Elec' Versions :**

The term 'Elec' in the model name indicates that the integral heating coils are electric in nature and that the product does not require to be connected to a separate fuel boiler. Any subsequent references to boiler or L.T.H.W. supply can therefore be ignored.



## INTERNAL COMPONENTS

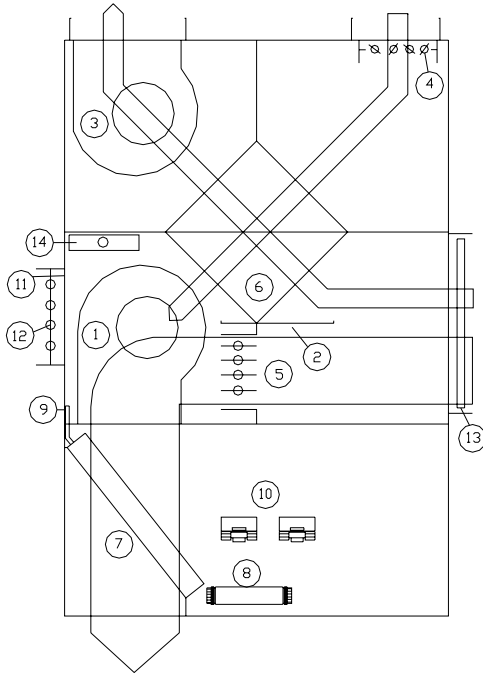

- 1 : SUPPLY AIR FAN
- 2 : CONDENSATE WATER COLLECTION TRAYS
- 3 : EXHAUST AIR TO OUTSIDE FAN
- 4 : FRESH AIR INTAKE LOUVRE & MOTOR
- 5 : AIR RECIRCULATION LOUVRE & MOTOR
- 6 : PLATE AIR TO AIR HEAT RECUPERATOR
- 7 : BOILER FED AIR HEATING COIL
- 8 : BOILER FED POOL WATER HEATING COIL
- 9 : BOILER PIPE WORK AIR BLEED VENT
- 10 : MOTORISED HEATING CONTROL VALVES
- 11 : BY-PASS FRESH AIR INTAKE LOUVRE & MOTOR
- 12 : FRESH AIR RATE / EXH. FAN CONTROLLER
- 13 : POOL AIR FILTER
- 14 : SPEED CONTROLLER

# PRINCIPLE OF OPERATION

## **LOCATION OF THE HEATSTAR PRODUCT :**

The Heatstar product would normally be positioned within an adjoining plant room with air duct channels taking air to and from the pool hall.

## **AIR MOVEMENT :**

The Heatstar product contains a large 'supply air' fan which continually draws in air from the pool hall and, subsequently, blows the same air back into the pool hall. Therefore, the pool hall air is 're-circulated' through the Heatstar product.

## **FRESH AIR DILUTION :**

To ensure that the pool hall air is maintained 'fresh' at all times, a level of mixture with outside fresh air is desirable :

Most of the air sucked from the pool hall is simply 're-circulated' back to the pool hall as described above.

However, a small amount of the pool hall air sucked into the Heatstar product is blown away to outside using an 'exhaust air' fan.

At the same time, an equally small amount of fresh air is allowed to be sucked into the Heatstar and then mixed with the air being re-circulated back to the pool hall.

## **HEAT RECOVERY ON FRESH AIR DILUTION :**

The pool hall air temperature will normally be very warm and, particularly during the winter months, the outside fresh air may be very cold.

Therefore, if you are blowing away warm pool hall air to outside and replacing it with cold fresh air, as occurs when the pool hall air is diluted as described above, then you are obviously losing heat and heat costs money!

To reduce the amount of heat lost in this way, the Heatstar incorporates a 'plate air-to-air heat exchanger'.

This is a simple non-mechanical device which consists only of a series of small channels through which air can pass. Both the warm pool hall air and the cold fresh air are passed through adjacent channels simultaneously, but are never mixed.

The channels through which the warm pool hall air is passed are positioned directly adjoining to the similar channels through which the cold fresh air is passed. As there is only a thin barrier separating the two different air channels, heat is transferred through the thin barrier from the warm pool hall air to the cold fresh air.

## **FULL FRESH AIR INTRODUCTION MODE - HIGH HUMIDITY :**

If the pool hall air becomes very humid, for instance if there is high activity within the pool hall, the Heatstar product automatically increases the amount of pool hall air which is blown away to outside.

A corresponding level of dry fresh air is then introduced to the pool hall through the Heatstar product.

Heat losses through ventilation with fresh air in this manner are limited by the actions of the plate heat recuperator.

### HEATING THE POOL HALL AIR :

The Heatstar product incorporates a heat transfer coil, again similar in appearance to a car radiator, which is plumbed to an independent fuel boiler on a closed loop circuit, similar to a domestic central heating system. The heat generated by the fuel boiler is allowed to be automatically transferred into the pool hall air whenever the pool hall air falls below the temperature setting.

### HEATING THE POOL WATER (SUPER PLUS VERSIONS ONLY) :

The Heatstar product incorporates a heat transfer coil (Heat exchanger) which is also plumbed to an independent fuel boiler. The heat generated by the fuel boiler is allowed to be automatically transferred into the pool water whenever the pool water falls below the temperature setting.

### CONTROLS :

The Heatstar product is able to operate completely automatically and incorporates a full control panel for this purpose.

## INSTALLATION REQUIREMENT SUMMARY

Installation connections required :	Super Plus	Super	AR Super Plus	AR Super	Elec Super Plus	Elec Super
Mains electricity supply	✓	✓	✓	✓	✓	✓
Air distribution ducts	✓	✓	✓	✓	✓	✓
Condensate water	✓	✓	✓	✓	✓	✓
Pool water pipes	✓	✓	✓	×	✓	✓
Fuel boiler pipes	✓	✓	✓	✓	×	×
External air heating motorised valve	×	✓	×	✓	×	×
Fuel Boiler demand signal	✓	×	✓	×	×	×
Fuel boiler By-pass valve	✓	×	✓	×	×	×

## APPLICATION NOTES

If a salt chlorination or electrolytic system is to be used on the pool then contact Heatstar immediately.

If there is no vapour barrier installed in the ceiling of the pool hall then problems will be incurred with condensation within the roof structure.

If there are no thermal breaks in aluminium window frames within the pool hall then condensation will occur on the frames. Any cold bridging within the pool hall building will result in condensation.

Any adjoining rooms open to the pool hall, such as changing rooms or toilets, should be heated to avoid condensation forming within these rooms.

If a 'one piece' plastic ceiling is to be used, then avoid removing the access panels on the Heatstar product while the fan is running, otherwise the ceiling may be damaged. Such ceilings will also be prone to move either up or down due to the ventilation effect of the Heatstar product. This is normal and should be expected.

Any wood used within the construction of the pool hall should be suitably treated in consideration of the possible variation in humidity levels and temperatures within the pool hall. Wood is a 'living' material and unsuitably treated wood can be expected to move, shrink or twist. The recommended range of conditions can be 30C +/- 15C and 60% RH +/- 30%.

The main air fan within the Heatstar will run continuously to provide even conditions and enable the humidity and temperature to be constantly sensed.

If the air temperature is not maintained at the correct level, when the pool is uncovered, the evaporation rate will increase dramatically and condensation may quickly become apparent.

It should be noted that swimming pool liners can be damaged if the pool water temperature is too high. If a pool liner is used, then the maximum temperature which the liner will stand should be confirmed and the pool water temperature maintained and monitored by the end user below that temperature.

## OFF LOADING & MANOEUVRING THE PRODUCT

The Heatstar is heavy and the use of lifting apparatus is advised to safely off load the product from the delivering lorry and to manoeuvre the product into position.

Do not drop or jar the product from any height - not even two or three inches. Move it gently and progressively. Do not lean the Heatstar by more than 60°. The Heatstar contains heavy motors which are mounted from the base.

The Heatstar can be damaged if due care is not taken, particularly the refrigeration system which may be fractured resulting in refrigerant loss.

Do not attempt to lift the Heatstar by the pipe outlets - this will cause damage and leaks.

The air duct work connection spigots on the Heatstar can be easily removed to aid access and the pipe connections can also be cut back if necessary.

## PLANT ROOM LAYOUT

The Heatstar should ideally be positioned in a plant room or other serviceable area, preferably adjoining the pool hall.

The plant room must be large enough to accommodate the Heatstar and to enable sufficient access for essential maintenance.

When positioning the unit take care not to obstruct any of the pipe connections or controls and **OBSERVE ACCESS WARNING LABELS ON THE HEATSTAR.**

The Heatstar cannot be positioned externally without a protective enclosure, unless it has been especially adapted.

If the plant room is not on the ground floor then anti-vibration measures may be necessary to prevent operational vibration transfer through the supporting floor.

# MINIMUM MAINTENANCE ACCESS

A minimum clearance of 900mm is required on the control panel side and 120mm minimum clearance on ALL other sides.

This represents the absolute minimum clearance required for essential maintenance.

Ideally, considerably greater access all around the Heatstar is desirable.

A minimum clearance of 900mm is required at the side of the pool air intake duct spigot in order to replace the air filter.

## MINIMUM ESSENTIAL MAINTENANCE ACCESS

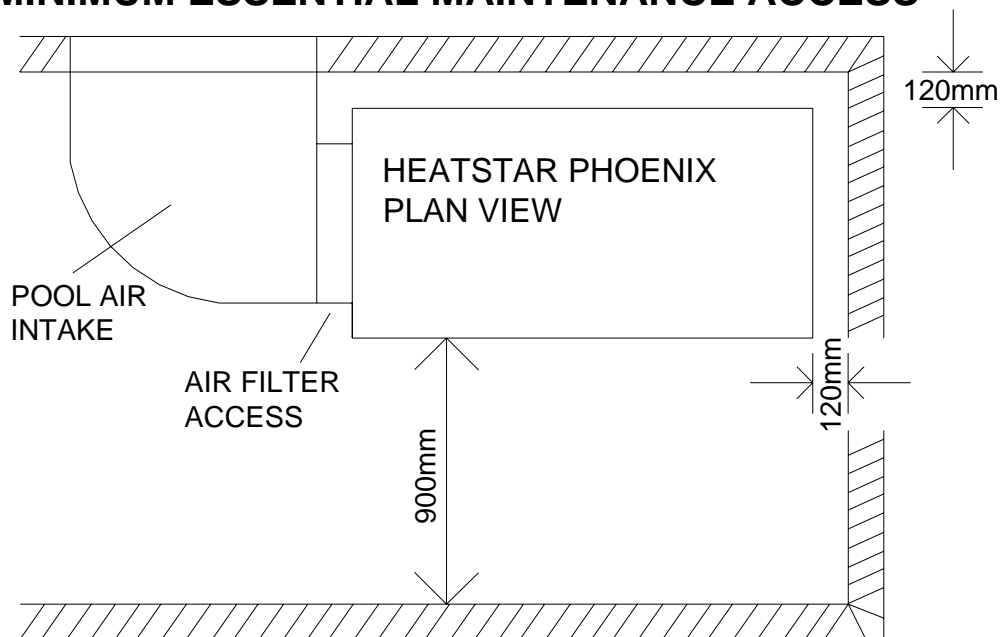

# POSITIONING THE PRODUCT

## LID OR BACK END SUPPLY AIR DISCHARGE VERSION :

Provide a firm, level plinth, capable of supporting the Heatstar.

The Heatstar will then simply sit on this plinth.

## BASE SUPPLY AIR DISCHARGE VERSION :

Provide a firm, level plinth, capable of supporting the Heatstar.

The discharge aperture, located on the base of the Heatstar, should be positioned directly over the entrance to the under ground supply air duct.

An effective air seal should be provided between the base of the Heatstar and the area around the entrance to the ducting.

If necessary, a 20 mm thick neoprene pad can be used. The pad, which should be sized to cover the entire base of the Heatstar, obviously needs a suitably sized hole cut into it for the air to pass through.

Alternatively, simply circle the floor hole a generous bead of exterior use silicon frame sealant, as well as around the base frame of the Heatstar. It may be necessary to tilt the Heatstar to aid access for this procedure and take all necessary care and assess all risks in doing so. The weight of the Heatstar will compress the sealant and form a good seal, even allowing for uneven floor slab.

# AIR DUCTING

## AIR DISTRIBUTION METHODS :

The heating and climate control product would normally be located in the pool equipment plant room. Therefore the heated / conditioned air supplied by the climate control product is ideally distributed around the pool hall using a ducting channel.

A ducting channel is a sealed void through which the air travels along on route to the pool hall. A typical ducting channel would be at least 500mm x 400mm in size and often much larger depending upon the amount of air flow required from the product. Outlet grilles would be used to allow the air to exit the ducting channel at the desired locations around the pool hall.

## DUCTING CHANNEL LAYOUT CONSIDERATIONS :

The ducting channel layout should be designed to ensure :

- The air is discharged via grilles directly onto areas prone to condensation, such as external glazing.
- There are no dead areas of the pool hall not covered with a movement of air.
- That the air flow velocity across the pool water surface is low.
- That operational noise transfer is reduced to a minimum.

Due consideration must be given to the position of the pool air intake and supply air ducting connections to the Heatstar.

All ducting should be sized and designed, together with grilles, dampers, bends, filters and noise attenuators not to exceed the specified maximum air resistance.

Initially all duct work sizes should be no smaller in area than the respective spigot connection holes on the Heatstar.

If in any doubt please contact Heatstar.

Care should be taken to ensure that the duct work is not routed across the maintenance access panels on the Heatstar.

If the pool hall is a 'log cabin' type construction, due allowance should be made for the 'setting' of the building when positioning wall grilles etc.

All ducting should be as close to air tight as practical.

Flexible ducting or multiple runs of small diameter ducts should not be used as this offers a high restriction on the flow of air. Drainage pipe cannot be used for the ducting.

## **POOL AIR INTAKE :**

The intake duct should be no smaller than the area of the pool air intake aperture on the Heatstar.

A flexible connection would notably limit the degree of noise transfer to the pool hall, as would the inclusion of at least a single 90° bend.

If noise transfer into the pool hall is considered an issue, then the inclusion of a noise attenuator or silencer in the duct is recommended.

Equally, it is recommended that the air intake spigot on the Heatstar should not be positioned directly through the pool hall wall as excessive noise transfer may occur.

The air inlet grille from the pool hall should have a free area of no less than 70% and should be no smaller in area than the pool air intake aperture on the Heatstar. Ideally it should be notably larger in order to reduce the air velocity and noise through the grille.

Alternatively, the plant room can be used as a plenum chamber for the pool hall air, with either a louvred door or grille allowing the pool hall air in. If this approach is adopted care should be taken to ensure that :

- The plant room is fully insulated and vapour sealed to pool hall standards.
- No chemical fumes can leak into in the plant room air.
- Any fuel boiler located within the same area is fitted with a sealed balanced flue.
- The fresh air intake duct work is well insulated to prevent condensation on the cold duct.
- Any cold water pipes or storage tanks are well insulated.
- Any electrics located within the plant room are housed within a suitably sealed enclosure.

In this instance, part of the casing of the Heatstar may be seen to sweat during cold weather due to the close proximity of cool fresh air within the unit, which is quite normal.

The pool hall air intake spigot houses an air filter, the access to which is through the side of the spigot. The connecting duct work should not obstruct the filter access.

If the duct work is exposed to cold outside air, then it should be thermally insulated and a vapour proof foil used.

## **SUPPLY AIR DISCHARGE DUCTING :**

### **UNDER FLOOR DUCTING :**

The entry hole to the under floor supply air duct requires to be positioned to accurately match up with the discharge hole on the base of the Heatstar.

Any duct work protruding from the entry hole should be cut back so that it is flush with the surrounding finished floor or plinth level.

If a high ground water table exists, under floor ducting should not be used due to the risk of the duct flooding and compromising the whole system. All under floor ducting should ideally be thermally insulated.

At least one water drainage point should be provided in the duct to enable any water which accidentally enters the duct via a hose etc. to be quickly removed.

### **OVERHEAD DUCTING :**

If the duct work is exposed to cold outside air or positioned in an un-insulated roof space then it should be thermally insulated and a vapour proof foil used.

It is important to seal the overhead duct as well as possible to avoid pool hall air leaking into the cold roof space.

A flexible connection between the Heatstar is and the ducting is advised to limit vibration transfer.

If there is to be both over head and under floor supply air duct work, then a manually adjustable damper should be positioned in the over head duct work in order to balance the air flow through each.

# FLEXIBLE DUCT CONNECTIONS

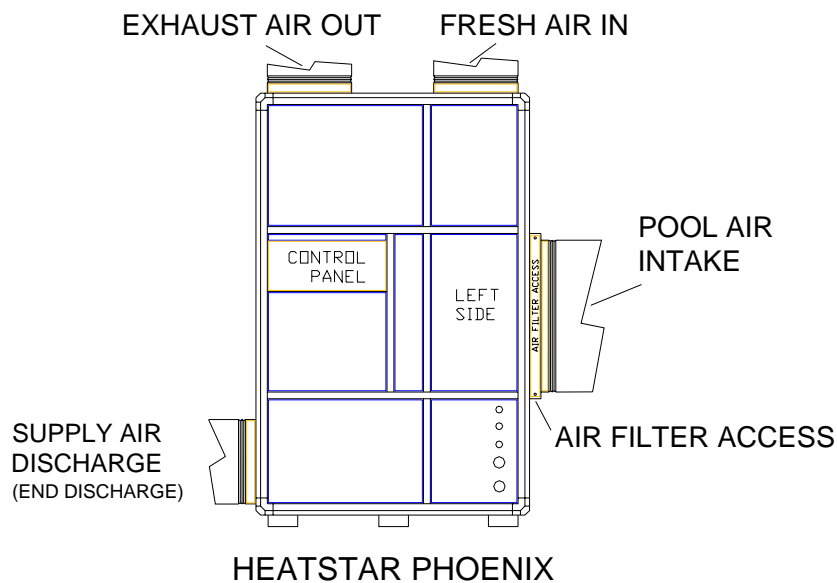

## FRESH AIR INLET & POOL AIR EXHAUST DUCTING :

Both the length and number of bends in the ducting supplying the Heatstar with fresh air, and the duct exhausting the pool hall air, should be kept to a minimum and should ideally not exceed 2m in length.

The grilles should be positioned to discourage air recirculation between the inlet and outlet. The duct openings to outside should be protected with suitable weather grilles to prevent birds and insects from entering.

The discharged air should not be obstructed by hedges, fences or walls and a minimum clearance of 800mm should be provided.

The fresh air intake should be positioned at least 1800mm away from any boiler flue outlet.

The exhaust air grille should preferably not be positioned directly under bedroom windows or towards adjoining properties to prevent noise intrusion.

If the recuperator by-pass fresh air induction facility is included as a special option, the by-pass duct connection can either be taken directly to outside or connected to the main fresh air intake duct.

If the pool hall air can normally enter the plant room, then the fresh air intake duct should be thermally insulated and vapour sealed to prevent condensation forming on the cold duct.

Flexible connections between the Heatstar and the ducting would help limit vibration transfer from the unit.



## **FRESH AIR INLET - RECUPERATOR BY-PASS (OPTION ONLY) :**

A second fresh air intake duct can be optionally specified to enhance the fresh air cooling effect during the summer months. The fresh air drawn through this second duct opening is not passed through the plate heat recuperator, therefore no heat at all is recovered to the incoming fresh air from the warm pool hall air being exhausted.

Effectively the fresh air drawn in is 'by-passed- around the plate recuperator, hence the term.

This second duct opening should be connected to the same fresh air intake duct as the main fresh air inlet opening.

# POOL WATER PIPE CONNECTIONS

The Heatstar requires connection into the pool water filtration pipe work :

## **POOL WATER FLOW SPECIFICATIONS :**

The required pool water flow rates and resistance through the Heatstar are detailed in the data contained within the 'Installation Services' document supplied with the product, further copy available on request.

## **PIPE WORK CONNECTIONS :**

The inlet and outlet to the Heatstar are connected via the return line going back to the pool i.e. after the pump and filter and before the chemical dosing.

The pool water inlet and outlet connections on the Heatstar are marked and must be connected as indicated.

The Heatstar has PVC stub connections suitable for solvent welds.

The Heatstar should be connected via unscrewable couplings.

It is suggested that the connection of the Heatstar is the last to be made in the pool water circuitry to prevent damage to the pipe stub connections on the Heatstar.

## **ROUTING OF PIPE WORK :**

Do not route pipe work across the service access panels of the Heatstar or the air filter access point.

All pipe work must be adequately supported for the operating weight when full of water with allowance made for expansion and contraction.

## **POOL WATER BY-PASS :**

A by-pass facility with isolation valves should be installed on the connections to the Heatstar. This will enable the pool filtration system to be operated normally in the unlikely event of a leak within the Heatstar.

If any valve positioned after the Heatstar is closed whilst the pool water circulating pump is still running, the increase in pressure may damage the Heatstar. It is therefore recommended that the handles be removed from such valves and placed inside the access panel of the Heatstar.

## **CHEMICAL DOSING :**

All purification devices and chemical injection systems must be fitted DOWN STREAM of the Heatstar. If they are before the Heatstar in the line of flow, then serious corrosion damage may occur to the Heatstar.

This includes the practice of dosing slow dissolving tablets via the skimmer or pump basket, which can result in concentrated corrosive liquids passing over metal components within the Heatstar. This relates to any slow dissolving tablets of ANY description, whether chlorine based or not.

Please note that the installation and usage instructions for the chemical dosing equipment often recommend that the chemical is introduced before the pool water filter. This should NOT be done unless the Heatstar is installed on a completely separate pipe circuit fed from an additional pool water pump.

## **NON-RETURN VALVE :**

If, when the pool water filtration pump is switched off or if the pool water pipe circuit is drained, chemicals introduced into the filtration system can be drawn through the Heatstar, a non-return valve must be fitted.

## **SALT WATER POOLS :**

In the past, salt chlorination or electrolytic water purification systems have been associated with a heightened risk of corrosion damage. Therefore, both the end user and the installer should duly consider that a heightened risk of corrosion damage may exist through the applications of such a device and that any corrosion damage to the Heatstar, however caused, is not covered by warranty.

## **INDEPENDENT POOL WATER HEATING METHODS :**

Any existing or independent method of pool water heating must be installed down stream of the Heatstar. In the event that a solar panel heating system is used in conjunction with the Heatstar, care should be taken to ensure that the flow rate of pool water through the filtration circuit is not reduced through the necessity to force water through the solar panel circuit.

## **POOL WATER CIRCULATING PUMP OPERATION :**

Effective operation of the Heatstar can only take place if the pool water filtration pump is providing an adequate flow of water to the unit. If the filter pump is not running then the Heatstar cannot operate correctly.

The pool water filtration pump can be operated on a time clock, as long as the pump is running during periods when the pool surface cover is not in place.

An option is available on the Heatstar to control the operation of the pool water pump directly from the Heatstar. This option must be specified prior to manufacture.

## **POOL WATER FLOW THROUGH HEATSTAR :**

The Heatstar is fitted with a water flow pressure sensor which controls the operation of the unit when the pool water filtration pump is not operating or insufficient pool water pressure is available. Under such circumstances the Heatstar will only be able heat the pool hall air and dehumidify with fresh air.

It is possible that the flow of pool water, although inadequate, may not be insufficient enough to trigger the water flow pressure sensor. It would then be possible for the Heatstar to cut-out on 'SYSTEM CUT-OUT' and the corresponding red neon will be lit. If this happens, the water flow should be fully restored and the Heatstar re-set, refer to 'fault finding'.

## **HEAD OF WATER :**

If a head of water exists above the Heatstar, then sensitive adjustment of the internal pool water flow pressure sensor may be necessary - please consult Heatstar for further details if required.

## **AIR VENTING OF POOL WATER PIPE WORK :**

If the Heatstar is positioned at a higher level than the pool water filtration equipment, then a facility for venting air from the pool pipe work will be required.

## **MAXIMUM PRESSURE AT HEATSTAR :**

The maximum working pressure at the Heatstar should not exceed 23 PSI.

## **FILTER BY-PASS ARRANGEMENT :**

It is possible to take the pool water flow for the Heatstar from between the pool circulating pump and the pool filter. This would then enable chemicals to be introduced into the filter without being passed through the Heatstar.

The limitation of this approach are that unfiltered pool water is passed through the Heatstar and that the volume of water passed through the filter is invariably reduced, retarding filtration efficiency.

However, the total resistance on the pool water circulating pump will be marginally reduced and the net flow increased as the pool water heat exchanger within the Heatstar would be in parallel with the pool filter and not in series.

# POOL WATER PLUMBING

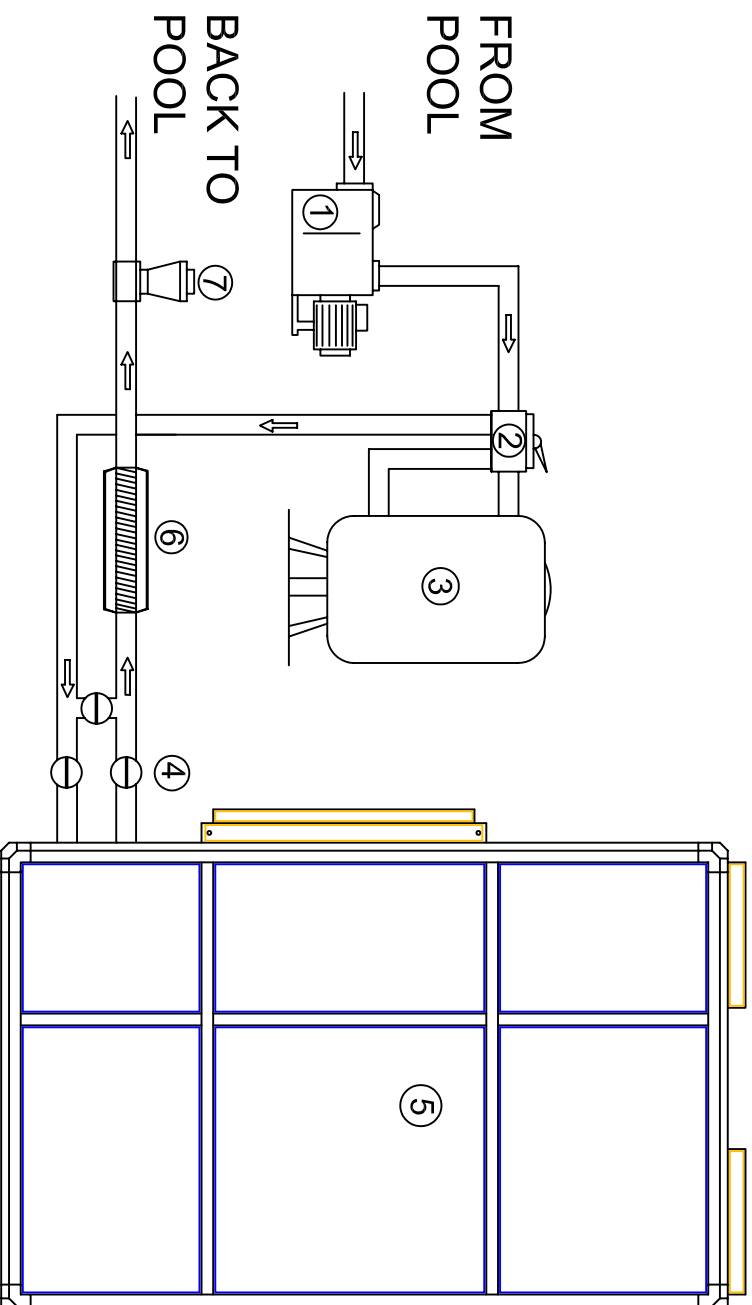

- 1 : POOL FILTERATION PUMP
- 2 : MULTI PORT VALVE
- 3 : POOL WATER FILTER
- 4 : MANUAL ISOLATION VALVES
- 5 : HEATSTAR UNIT
- 6 : INDEPENDANT HEATER (IF APPLICABLE)
- 7 : CHEMICAL DOSING

# FUEL BOILER SYSTEM PIPE CONNECTIONS :

## **ABOUT THE HEATING CIRCUIT :**

A separate fuel boiler is used to provide a source of heat.

The Heatstar simply transfers the heat provided by the fuel boiler into the pool hall air / pool water.

The heat produced by the fuel boiler is taken to the Heatstar using a closed circuit of pipe work filled with water, similar in principle to a standard central heating system.

The fuel boiler heats up the water within the closed pipe circuit, which the boiler circulating pump then pumps through the pipe work to the Heatstar.

The Heatstar transfers this heat from the closed pipe circuit, prior to the water being re-circulated back to the fuel boiler for the heating process to continue.

This type of circuit is known as an L.T.H.W. system (Low Temperature Hot Water).

## **FUEL BOILER TYPE :**

The boiler required is a normal domestic / commercial type, identical to that which would often be used to provide heat to standard radiators.

A specialised 'swimming pool' boiler cannot be used as these can usually only be used to heat the pool water and not the pool hall air.

High efficiency condensing boilers can be used.

Pressurised system boilers can be used as long as the pressure is not normally allowed to exceed 25 P.S.I.

A balanced flue arrangement is preferable and necessary if the pool hall air can enter the boiler plant room.

Two smaller boilers can be used, in place of a single large boiler, if this offers any plant room space benefits.

## **BOILER SIZE :**

The amount of heat which a boiler is capable of producing is described as the boiler out put capacity. This should not be confused with the boiler input rating which is not the same.

This will normally be rated in BTU's (British Thermal Units) or kW. (3412.14 BTU's = 1 kW ).

The required boiler heat output rating are detailed in the data contained within the 'Installation Services' document supplied with the product, further copy available on request.

Contact Heatstar if there is any doubt as to the correct out put rating.

## **BOILER WATER CIRCULATING PUMP :**

The required boiler circulating pump flow rate performance is detailed in the data contained within the 'Installation Services' document supplied with the product, further copy available on request.

Often, a domestic type pump will not be adequate in performance. Likewise, if the boiler circulating pump is built into the boiler, then the pump will often not be adequate in performance.

The boiler water circulating pump can be wired to run on demand from the Heatstar.

## **L.T.H.W. SPECIFICATIONS :**

The required L.T.H.W. flow temperatures, rates and resistances are detailed in the data contained within the 'Installation Services' document supplied with the product, further copy available on request.

If the L.T.H.W. supply provided to the Heatstar falls short of these requirements, then the full heating capacity will not be achieved.

## **BOILER PIPE CONNECTIONS TO HEATSTAR :**

The pipe connections, which are labelled, should be made with compression fittings. Soldered or brazed connections should not be used as the excessive localised heat will damage the casing of the unit and may damage internal pipe connections.

The compression connections should be able to be unscrewed to disconnect the unit for maintenance.

## **MOTORISED HEATING VALVES :**

The motorised heating valves are simple 'two port' electric valves which, when electrically powered open, allow the flow of hot water from the boiler into the heat exchange coils to enable heating. When the power is removed, the valve is closed automatically by a spring to prevent the flow of hot water from the fuel boiler. Such valves are commonly used within domestic central heating systems.

### **Heatstar 'Super' versions :**

Heatstar Super versions only incorporate the air heat exchange coil and not any motorised heating valves, so an external motorised heating valve will need to be provided by the installer.

The external motorised heating valve is powered electrically from the electrical connections within the Heatstar .

The system is compatible for use with either two port or three port external motorised valves.

If external two port valves are used, then a by-pass would also be necessary.

The external valve can either be 'spring close' or 'power close' in type.

The external heating valve should open and allow L.T.H.W. to the air heating coil when electrical power is provided.

The electrical supply to the valve from the Heatstar is a switched 230v 1 Amp supply which is either on or off and not proportional.

### **Heatstar 'Super Plus' versions :**

Heatstar Super Plus versions incorporate the air heat exchange coil, the main pool water heat exchange coil AND motorised heating valves to control both.

Therefore, with a 'Super Plus' version, no external heating valve is necessary.

## **BY-PASS PIPE ('SUPER PLUS' VERSIONS ONLY) :**

The internal heating valves are two way and, to prevent the possibility of the boiler circulation pump running against a dead end when both motorised valves are in the closed position, we recommend that a by-pass be included in the L.T.H.W. pipe work.

The by-pass should be controlled by a pressure pre-set valve which should be adjusted to provide the correct flow through the Heatstar when either one or both of the internal zone valves are in the open position.

Alternatively, it is possible to use a dedicated motorised valve as the by-pass. Such a valve would be powered open when both internal air and water heating valves were closed.

**DRAIN DOWN VALVES :**

Drain down valves should be provided at appropriate points around the boiler pipe work circuit.

**ROUTING OF PIPE WORK :**

Do not route pipe work across the service access panels of the Heatstar or the air filter access point.

**INSULATION OF PIPE WORK :**

All L.T.H.W. pipe work should be thermally insulated to prevent heat loss.

**AIR VENTING OF THE L.T.H.W. PIPE WORK :**

An air vent is positioned on the top section of the air heating coil within the Heatstar.

An air vent should also be positioned at the highest point in the L.T.H.W. pipe circuit.

**ISOLATION VALVES :**

A method of isolating the flow of L.T.H.W. through the Heatstar should be included within both the flow and return pipe connection. This will enable maintenance to be carried out on the L.T.H.W. pipe circuit within the Heatstar without the need to drain down the entire pipe circuit.

**BOILER MANUFACTURERS DATA :**

Always refer to current building control regulations, together with the boiler and boiler circulating pump manufacturers installation information prior to designing or installing the heating circuit.

# BOILER PLUMBING HEATSTAR SUPER PLUS VERSIONS

- 1 : FUEL BOILER
- 2 : BOILER WATER CIRCULATING PUMP
- 3 : MANUAL BY-PASS VALVE
- 4 : MANUAL ISOLATION VALVES
- 5 : HEATSTAR UNIT- INC. AIR AND WATER HEAT EXCHANGE COILS

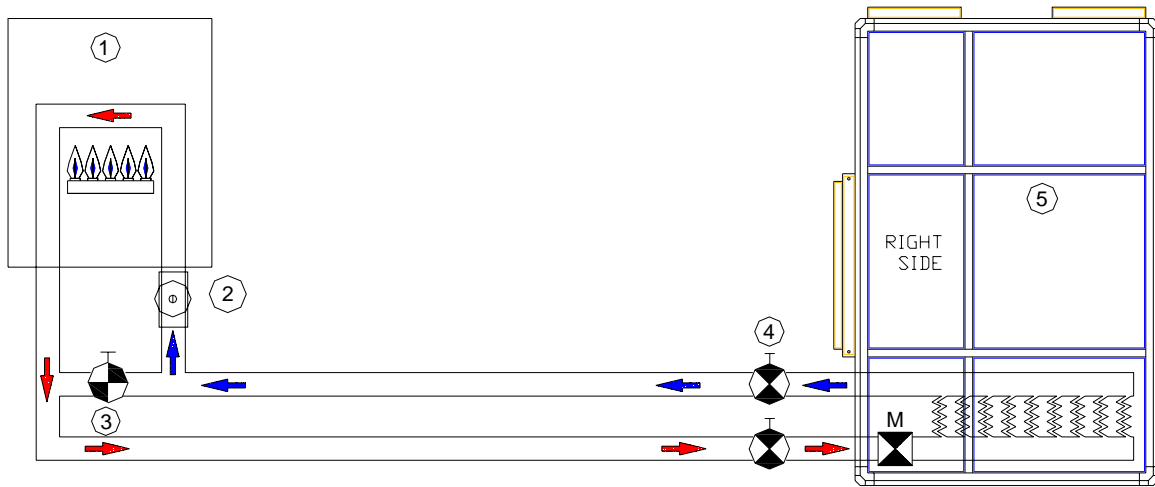

# BOILER PLUMBING HEATSTAR SUPER VERSIONS

- 1 : FUEL BOILER
- 2 : BOILER WATER CIRCULATING PUMP
- 3 : MANUAL BY-PASS VALVE
- 4 : MANUAL ISOLATION VALVES
- 5 : HEATSTAR UNIT - INC. AIR HEAT EXCHANGE COIL
- 6 : MOTORISED HEATING VALVE - AIR HEATING
- 7 : MOTORISED HEATING VALVE - POOL WATER HEATING
- 8 : POOL WATER HEAT EXCHANGER

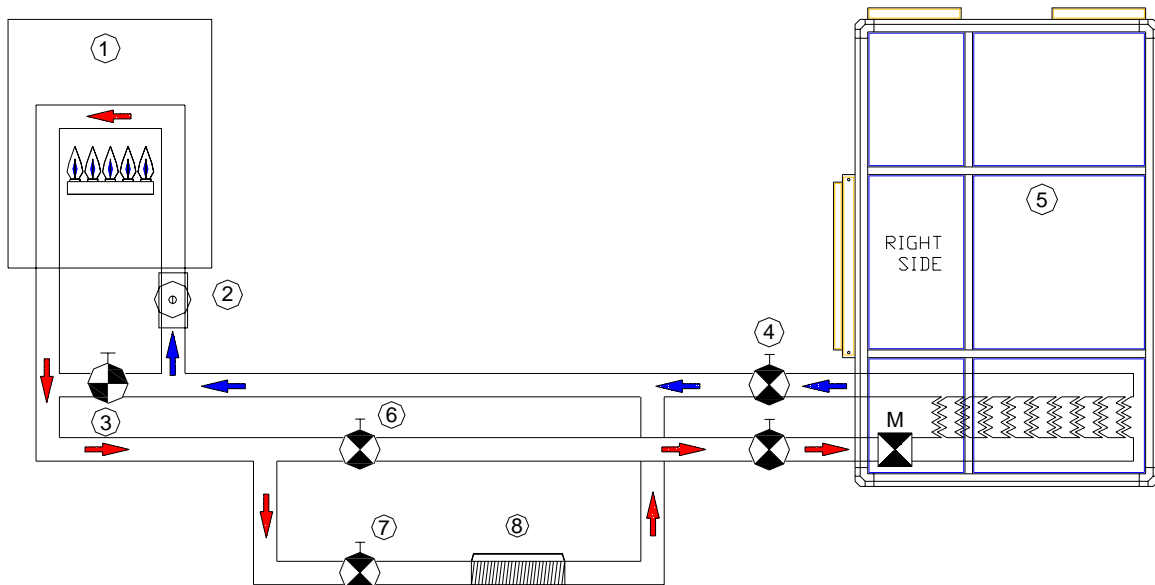



# ELECTRICAL CONNECTIONS

## **WARNING**

The Heatstar embodies electrical and rotational equipment.

Only qualified personnel who thoroughly understand the operation of this equipment and any associated machinery should install, start-up or attempt maintenance of this equipment. Non-compliance with this warning may result in personal injury and / or equipment damage.

Never work on any control equipment without first isolating all power supplies from the equipment.

## **STANDARDS AND REGULATIONS**

All relevant national standards and local electricity board regulations must be observed at installation.

## **ELECTRICAL CONNECTIONS**

The mains electricity supply is connected to the manual isolator switch on the end of the Heatstar.

All other control circuit connections are made to the terminals located behind the main service access panel, below the control panel. The access panel simply unscrews to reveal the terminals.

## **ELECTRICAL CONNECTIONS REQUIRED**

### **ALL MODELS :**

MAINS power electricity supply TO Heatstar .

Electric pool surface cover interlock (12 volt switched link).

### **‘SUPER’ VERSIONS ONLY :**

230v power electricity supply, FROM Heatstar TO external air heating motorised valve.  
This electricity supply is present when the Heatstar senses a demand for air heating.

### **‘SUPER PLUS’ VERSIONS :**

230v power electricity supply, FROM Heatstar, TO fuel boiler and / or boiler water circulating pump.  
This electricity supply is present when the Heatstar senses a demand for air or pool water heating.

230v power electricity supply, FROM Heatstar, TO external boiler water by-pass motorised valve.  
This electricity supply is present when the Heatstar senses that there is no demand for air or pool water heating.

# ELECTRICAL CONNECTIONS

SUPER PLUS VERSIONS (3 PHASE MODEL SHOWN)

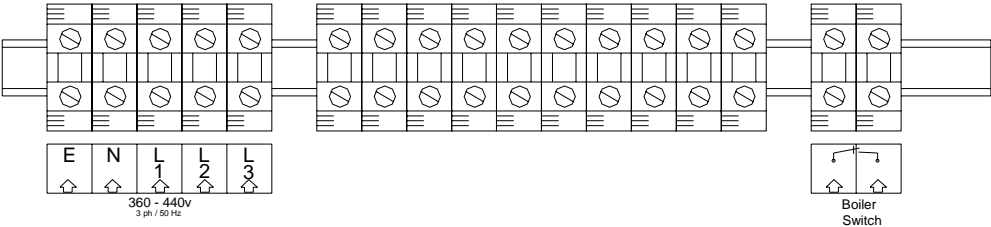

SUPER VERSIONS (3 PHASE MODEL SHOWN)

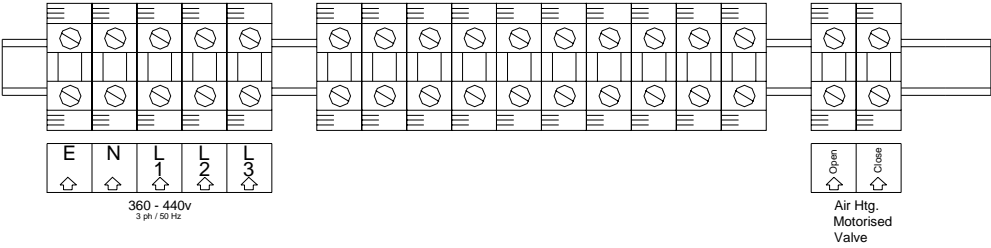

# ELECTRICAL SAFETY PROTECTION REQUIRED

## **EARTHING :**

The Heatstar must be electrically connected to an appropriate safety earth. Failure to do so presents an electrical shock hazard.

The circuit protection to the Heatstar should allow for two separate aspects, being a Residual Current Device and Miniature Circuit Breaker.

## **RCD :**

The mains power electricity supply to the Heatstar should be routed via a suitably sized Residual Current Device (RCD).

An RCD is sometimes referred to as a Residual Current Circuit Breaker (RCCB) or Earth Leakage Circuit Breaker (ELCB).

An RCD rating of 30mA is advised.

The purpose of the RCD is to protect against fatal electric shock to personnel, by reducing to safe levels (not eliminating) the value and length of time a person is exposed to current flow through the body.

Equally the RCD will help protect plant and equipment from fires started by low fault currents passing from Live to Earth, that a normal fuse or circuit breaker may not detect.

## **PHASE PROTECTION :**

If the mains electrical supply is Three Phase in nature, then phase protection must be provided as part of the circuit protection.

This is to guard against the possibility of one or two of the phases being temporarily isolated due to a power cut etc.

If all three phases are not isolated together, at exactly the same time, then the large electric motors within the Heatstar can be damaged. Such damage is not covered under the manufacturers warranty.

## **CIRCUIT BREAKER :**

In addition to an RCD, the mains supply to the Heatstar must be protected by a Miniature Circuit Breaker (MCB).

An MCB is a circuit overload protection device similar to a simple fuse, but re-settable.

An MCB normally has two modes of operation :

Thermal Overload Protection - to protect cabling and equipment from 'long term' over current damage.

Magnetic Short Circuit Protection - to protect cabling and equipment against very high fault currents caused by terminal component failure.

An MCB is rated by the normal carrying current, normal carrying voltage and by the maximum fault current and voltage they can safely / repeatedly break.

As the Heatstar incorporates large electric motors, with high initial starting current loads, we recommend the use of a 'Type C' MCB, which allows for this initial starting load.

Standard fuses should not be used in place of a proper MCB.

## **ROUTING CABLES INTO THE HEATSTAR :**

Form an appropriately sized hole at a convenient location in the unit case to route the control wires to the electrical terminal connections. The cables should be encased in conduit where routed through the unit. Take care not to damage any internal component or position the cables where they can be drawn into the fans.

# MAINS ELECTRICITY SUPPLY

## **MAXIMUM SUPPLY LOADS :**

The required electrical specifications are given within the 'Installation Services' document supplied with the product and also on the unit data plate.

The Heatstar incorporates the supply fan motor, the extract fan motor and, largest of all, the refrigeration compressor motor.

The starting of the motors are off set using time delays to limit the starting electrical load.

The initial load drawn, for a fraction of a second, by each of the motors on starting, will be approximately three times the normal running Amps.

The normal running amps drawn by the Heatstar will vary depending on the pool hall temperature/humidity conditions and the pool water temperature. This is due to internal working pressures within the refrigeration system and is quite normal.

## **SUPPLY VOLTAGE :**

The voltage limits indicated in the Electrical Specifications must not be exceeded.

The correct voltage must be available under the Starting Load Current.

## **POWER CABLE SIZING :**

The Heatstar must be connected with the correct cable size. If the electrical cable size is too small, the voltage will be restricted and the internal electrical motors could be damaged.

The cable supplying electricity to a machine with a given electrical load must increase in cross sectional area as the length increases in order that the voltage drop within the cable does not exceed the recommended limits.

Therefore, give particular consideration to cable size if there is a long cable run.

Power cables must have a minimum rating of 1.1 x Full Load Current.

The mains cable should be run in Conduit or armoured casing.

## **CONTROL AND SWITCH GEAR :**

No motor starter, thermal over load or other switch gear should be connected on the mains power supply to the Heatstar.

The Heatstar requires a continuous mains power supply, 24 hours per day. Therefore time clocks etc. should not be installed.

The fan motors within the Heatstar are designed for prolonged continuous operation and regular start / stopping will reduce their service life.

## **HIGH VOLTAGE TEST :**

Never perform high voltage resistance checks on the mains wiring without first disconnecting the Heatstar from the circuit being tested.

## PHASE ROTATION :

If the Heatstar is to be run on a Three Phase electricity supply, the direction of fan rotation must be visually confirmed to be correct on first connection of the mains supply. This is normally the responsibility of the electrical contractor.

# FAN ROTATION DIRECTION

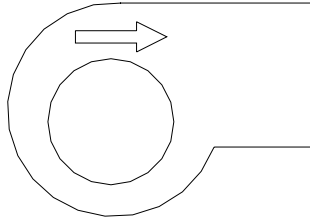

# EXTERNAL AIR MOTORISED VALVE (Super version only)

This would apply to Heatstar 'Super' versions only.

A separate external motorised heating valve to control air heating should be provided within the boiler pipe circuit supplying the Heatstar.

This valve is to be electrically powered open and close by the Heatstar.

A 230v Single phase live supply is provided from the Heatstar to power the valve open.

If the motorised heating valve is of 'spring return' type, then the valve will close automatically as soon as the 230v supply from the Heatstar is switched off.

If the motorised heating valve is of 'power close' type, then a separate 230v supply is provided from the Heatstar to power the valve close.

A Neutral and Earth connection should also be made to the external motorised valve from the Heatstar electrics.

The maximum current available from the Heatstar for this purpose is 3 Amps.

If the current loading of the motorised heating valve exceeds this rating, then a separate suitably sized relay should be installed to switch the electricity to the valve.

## FUEL BOILER DEMAND SWITCH (Super Plus only)

This would apply to Heatstar 'Super Plus' versions only.

To completely switch off the boiler and/or circulation pump during periods when heating is not required, an electrical switch is provided in the Heatstar, see electrical connections.

This is a 230v 3 Amp live electrical signal switch, which is an extension of the auxiliary contacts located within the internal motorised valves.

The switch signal is present when the Heatstar requires heat from the boiler to heat either air, pool water or both. The signal is not present when no heat is required from the boiler.

It is recommended that boiler is dedicated solely to the Heatstar.

However, if other separate heating systems are fed from the same fuel boiler, i.e. radiators etc, then this switch would have to be wired in parallel, via an electrical relay, with the contacts of any other motorised heating valves linked to the same fuel boiler.

The boiler demand switch is a safety protection device and helps guard against excessive over-heating of the pool water in the event of a fault condition. Therefore the switch should be connected and confirmed to be operating correctly.

The use of the boiler demand switch will also contribute to energy efficiency by switching off the boiler completely during period of no demand of heat.

The fuel boiler supplying heat to the Heatstar should not be governed by any form of time clock control. The Heatstar may call for heat from the fuel boiler at any time, day or night, and, if that heat is not available, then control of the pool hall environment will be compromised.

The electrical supply to the boiler should be routed from the Heatstar, via an MCB and local isolator switch.

To aid future maintenance to the fuel boiler system, it is advised that the boiler MCB & Local isolator are marked and labelled to clearly indicate that the electrical supply is routed via the Heatstar and will only be present intermittently.

## WIRING THE BOILER WATER CIRCULATING PUMP

It is advised that the boiler water circulating pump is wired to only operate on demand of heat, in line with UK building control regulations.

To prevent the possibility of the pump operating against a dead end, it should be confirmed that :

- A by-pass pipe / valve facility has been included within the boiler water pipe circuit to the Heatstar.  
Or, that any external motorised heating valves are 3 way in type i.e. simply divert, as opposed to shut off, the flow of water from the boiler.

## WIRING AN EXTERNAL BY-PASS VALVE (Super Plus only)

If it is not practical to dedicate the function of the fuel boiler and boiler pump to the Heatstar, it may be necessary to install a motorised by-pass valve. This valve should remain closed when the Heatstar was demanding heat but should automatically open when the Heatstar is no longer demanding heat and the motorised valves within the Heatstar have closed.

A 230v electrical supply is available from the Heatstar for the purpose of powering open the by-pass valve when heating is no longer required.

## BOILER OVERRUN

With some larger output fuel boilers, it is advisable to install a relay to enable the boiler pump to 'run on' for a short period of time in order to dissipate any residual heat from the boiler. This facility can be specified as an option within the Heatstar.

## POOL COVER INTERLOCK

If an electric automatic pool surface cover is to be used on the swimming pool, then it is possible to electrically link the cover control box to the Heatstar, so that 'air temperature set back' mode is automatically selected as soon as the cover closes across the pool and 'normal air temperature' mode automatically selected as soon as the cover is opened.

The electrical link in the Heatstar comprises of a pair of terminals – one terminal has a 12v feed, if this feed is switched via a remote relay so that it connects to the second terminal, then 'cover open' mode is selected. The relay requires to maintain a 'closed circuit' status and cannot be momentary.



# ELECTRICAL INSTALLATION SCHEMATIC

## SUPER PLUS VERSIONS

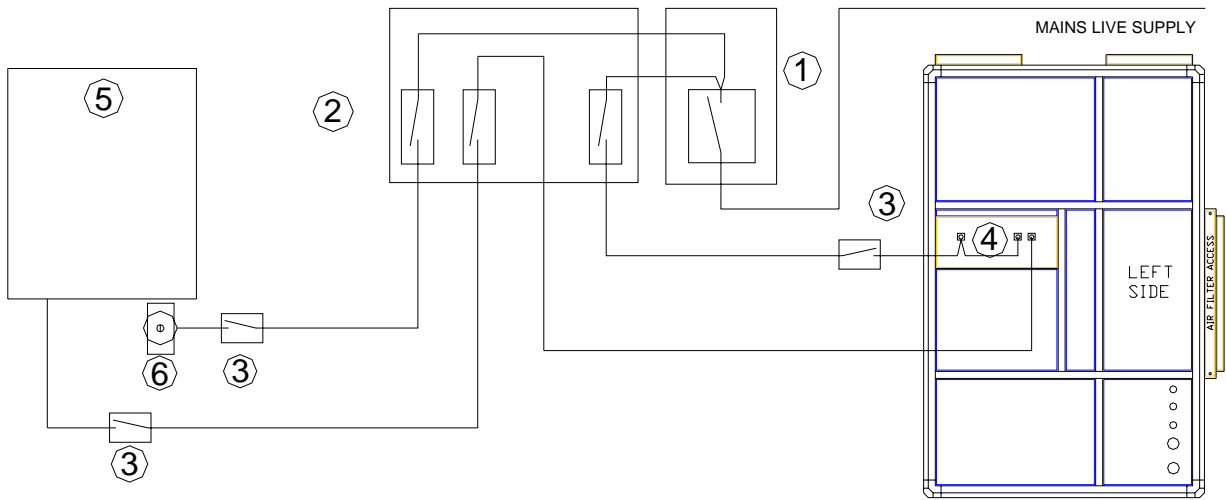

## SUPER VERSIONS

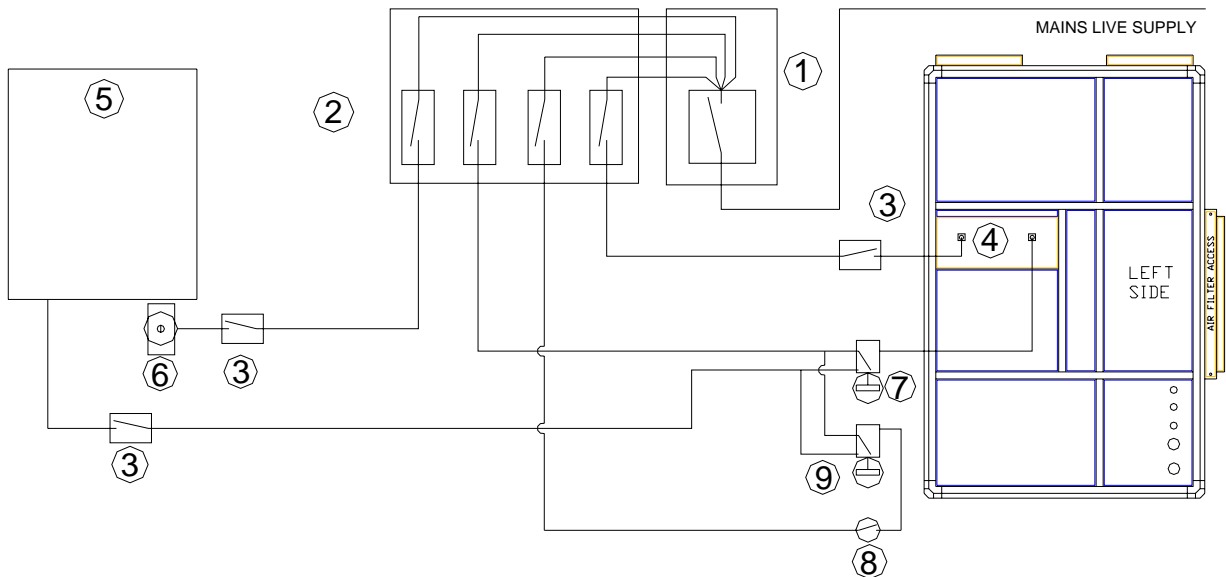

- |  |  |
|--|--|
| 1 : RCD                                  | 6 : BOILER CIRCULATING PUMP            |
| 2 : MCB                                  | 7 : AIR HEATING MOTORISED VALVE        |
| 3 : LOCAL ISOLATOR SWITCH                | 8 : POOL WATER TEMPERATURE STAT        |
| 4 : HEATSTAR UNIT ELECTRICAL CONNECTIONS | 9 : POOL WATER HEATING MOTORISED VALVE |
| 5 : FUEL BOILER                          |  |



# PRINCIPLE OF CONTROLS

## **CONTROL OPERATION :**

The controls on the Heatstar are intended to ensure that the pool hall environment is constantly maintained at the correct conditions in terms of temperature and humidity.

The controls monitor the actual conditions within the pool hall at all times and automatically switch 'ON' or 'OFF' heating or dehumidification accordingly.

All the controls operate on a simple 'ON' or 'OFF' principle.

Air heating, for example, will either be 'ON', if the pool hall air temperature is colder than the control setting, or 'OFF', if the pool hall air temperature is warm enough.

The control setting simply tells the Heatstar what temperature you consider to be 'warm enough'.

The heat output available from the Heatstar is a fixed quantity and increasing the control setting will not serve to increase the amount of heat coming from the Heatstar at all.

The controls are intended to be completely automatic and, once correctly set up, they should not require any further adjustment at all.

## **CONTROL OF CONDITIONS :**

All conditions within the pool hall are controlled at the same level at all times, for example :

Pool water temperature	-	Always heated up to 28°C
Pool hall air temperature	-	Always heated up to 30°C (*)
Pool hall humidity level	-	Always dehumidified down to 65% R.H.

(\*) The pool hall air temperature normally requires to be maintained slightly warmer than the pool water temperature.

If a pool surface cover is used, then the pool hall air temperature can be 'set back' to the lesser temperature of 22°C during the periods when the pool cover is in place. The Heatstar has a 'dual' air temperature control for this purpose.

# ABOUT THE CONTROLS

The controls are digital electronic in nature offering easy initial setting up and the benefit of an actual display of the actual monitored pool hall temperature / humidity.

The temperature readings on the thermostats in '°C' and, '% Relative Humidity' on the humidity stat.

Note that the temperature and humidity readings displayed by the controls relate to the conditions at the location of the Heatstar and may differ slightly from those measured within the actual pool hall.

Normally the stats will display the actual temperature or humidity, as measured at the time.

The stats will already be factory pre-set to maintain typical conditions when the unit is first switched on.

## **To change the desired air temperature setting :**

Press and release button 'L1' to display the temperature set point for 'uncovered pool mode', typically 30°C. To increase or decrease the set point, simply use the up or down arrow buttons.

Press and release button 'L2' to display the temperature set point for 'covered pool mode', typically 22°C. Again, to increase or decrease the set point, simply use the up or down arrow buttons.

After a few seconds, the control we resume displaying the current actual pool room air temperature.

## **To change the desired pool water temperature setting :**

On the digital thermostat, press and hold the left hand button (the one with both up and down arrows), which will then display the set point temperature.

To increase the set temperature, whilst still pressing the left hand button, press the button by the 'up arrow'.

To decrease the set temperature, whilst still pressing the left hand button, press the button by the 'down arrow'.

When the left hand button is released, the new set temperature is fixed and the thermostat reverts to displaying the actual current pool water temperature.

## **To change the humidity setting :**

Press and release the L1 button to display the set humidity, typically 60%, and use the up and down arrowed button to alter the setting, as per the air heating stat.

# ABOUT THE HEATSTAR CONTROL PANEL

## **'POWER' Neon -**

This neon, when lit, indicates that mains electricity is being supplied to the Heatstar.

## **'POOL WATER FLOW CUT-OUT' Neon -**

This neon, when lit, indicates insufficient pool water flow through the Heatstar.

Should this light, please refer to fault finding.

No pool water heating is possible until the pool water flow has been restored, although the fans will still operate and air heating is still possible.

## **'DEHUMIDIFICATION' Neon -**

The neon, when lit, indicates that increased fresh air induction is being used to reduce the pool room humidity level.

The control setting determines at which level of pool hall air humidity this process occurs.

To adjust control setting :-

Go to the 'HUMIDITY' electronic air humidity stat.

Press the button L1.

The stat now displays the 'DEHUMIDIFICATION HUMIDITY SETTING'.

Adjust the setting accordingly.

Typically the dehumidification system will activate when the pool hall air humidity level rises to over 60%, automatically switching 'OFF' should the pool hall air humidity fall below this level again.

If the neon is not lit, then the pool hall humidity is below the switching 'ON' level and this is quite usual.

The pool hall air humidity may be expected to rise to this level when the pool is in normal use.

The bottom row of the control panel relates to the primary heating of the pool hall air and pool water.

## **AIR TEMPERATURE CONTROL**

There are 'dual' air heating settings to facilitate a high pool hall air temperature when the pool is uncovered and in use and a lower 'set back' pool hall air temperature when the pool is covered with a surface cover.

If no pool surface cover is used, then the pool hall air temperature has to be maintained at the higher temperature at all times.

When the neon is lit, then air heating is switched 'ON'.

## **AIR TEMPERATURE SETTING - SET BACK LEVEL - POOL COVER ON POOL :**

The control setting determines at which level of pool hall air temperature the air heating switches 'OFF' when in 'pool cover on' mode.

To adjust control setting :-

Go to the 'AIR TEMPERATURE' electronic air temperature thermostat.

Press the button L2.

The stat now displays the 'SET BACK LEVEL TEMPERATURE SETTING'.

Adjust the setting accordingly.

Typically the air heating will be 'ON' until the pool hall air temperature level heats up to 22°C, then it would switch 'OFF', switching back on automatically should the air temperature fall again.

This should relate to the period when the pool is covered with a surface blanket.

#### **AIR TEMPERATURE SETTING - 'IN USE' LEVEL - POOL COVER OFF POOL :**

The control setting determines at which level of pool hall air temperature the air heating switches 'OFF' when in the 'pool cover off' mode.

To adjust control setting :-

Go to the 'AIR TEMPERATURE' electronic air temperature thermostat.

Press the button L1.

The stat now displays the 'IN USE LEVEL TEMPERATURE SETTING'.

Adjust the setting accordingly.

Typically the air heating will be 'ON' until the pool hall air temperature level heats up to 30°C, then it would switch 'OFF', switching back on automatically should the air temperature fall again.

This should relate to the period when the pool is NOT covered with a surface blanket.

#### **POOL COVER ON / POOL COVER OFF MODE - AUTO SELECTION TIME CLOCK :**

Most swimming pools are used to a daily routine, therefore the times when the pool surface cover is likely to be on can be pre-determined.

The time clock is used to automatically select between the pool cover on 'set back' air temperature setting and the pool cover off 'in use' air temperature setting.

Pull the segments out to SHOW RED to define the POOL COVER ON 'set back' period. This will typically be during the night and during periods of the day when no use of the pool is anticipated.

When setting the time clock allow up to 30 minutes for the air temperature to heat up to the 'in use' temperature before the pool cover is scheduled to be removed.

#### **POOL COVER ON / POOL COVER OFF MODE - MANUAL SELECTION SWITCH :**

The switch can be used to by-pass the set periods on the time clock to manually select the 'in use' air temperature control setting at any time of the day.

For example, should there be a requirement to use the pool during the night when the pool surface cover is normally on, simply move the switch to 'Normal Control' to initiate the 'in use' pool hall air temperature setting.

When use of the pool is finished and the cover put back on, return the switch to 'Time Clock Control' position.

If no pool surface cover is used, then the switch should be set in the 'Normal Control' position at all times. If this is the case, then the set up of the time clock is irrelevant.

#### **LINK FROM HEATSTAR INTO AUTOMATIC POOL COVER CONTROL BOX**

If the Heatstar has been electrically connected into the control box of an automatic pool surface cover, then the time clock must be set as follows :

Pull all the segments on the time clock out so that red is visible all the way round for 24 hrs.

Set the manual rocker switch to 'time clock'.

The Heatstar will then maintain 'air temperature set back' mode at all times, unless the pool surface cover is opened.

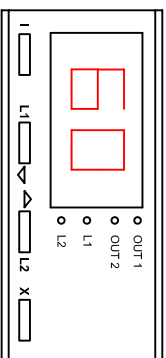

HUMIDITY



DEHUMIDIFICATION



POWER



POOL WATER  
CUT-OUT

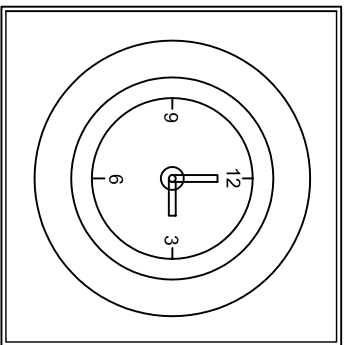

AIR TEMPERATURE SET BACK

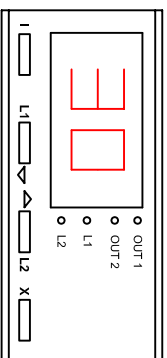
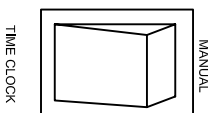
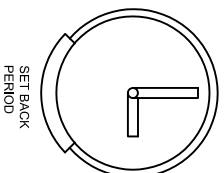

AIR TEMPERATURE



HEATING

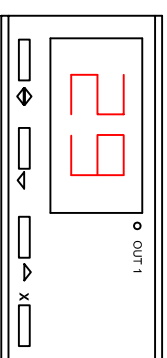

WATER TEMPERATURE



HEATING

## **POOL WATER TEMPERATURE CONTROL ('Super Plus' versions only) -**

The neon, when lit, indicates that POOL WATER HEATING is switched 'ON' to achieve the pool water temperature setting.

The control setting determines at which level of pool water temperature the water heating switches 'OFF'.

To adjust control setting :-

Go to the 'WATER TEMPERATURE' Electronic Water Temperature Stat.

Press and hold the left button.

The stat now display the 'POOL WATER TEMPERATURE SETTING'.

Adjust the setting accordingly.

Typically the pool water heating will be 'ON' until the pool water temperature level heats up to 29°C, then it would switch 'OFF', switching back on automatically should the pool water temperature fall again.

Although the air can be heated up comparatively quickly, it will take a very long time, as long as 24 hours, for the pool water temperature to rise or fall even one degree in temperature. It is therefore very important not to change the temperature setting more than one degree per day, otherwise the temperature balance may be lost.

Please note : All neon indicators will glow dimly even when they are not lit and this is quite normal. This effect can be enhanced if the electricity supply is hydro-electric in nature.

## **SUMMER SWITCH (Option only) –**

This option can be specified for use with sliding type pool enclosures which, during the summer months, could be left open for several days at a time to enable the pool to effectively be used as an 'outdoor' pool.

A manual switch is provided on the Heatstar to switch off all aspects of environmental control, including the fans, but to leave the pool water heating circuit active to maintain the correct pool water temperature during such times.

When the pool enclosure is closed up again, the summer switch should be used to re-establish environmental control.

## **INITIAL CONTROL SETTINGS**

The controls should initially be set as follows :

CONTROL	SETTING	
DEHUMIDIFICATION -	L1	60 : Dehumidification switch on point.
AIR TEMPERATURE -	L1	30 : 'In use' period heating switch off point.
	L2	22 : 'Set back' period heating switch off point.
POOL TEMPERATURE -	LH	29 : Heating switch off point. (Super Plus Only).



# STARTING THE HEATSTAR

The Heatstar will start to operate as soon as the mains electricity supply is connected.

The unit can only be properly operated when all the installation services are complete i.e. electricians, air distribution duct work, pool water filtration pipe work, boiler circuit pipe work etc.

The Heatstar cannot be started until the pool is full of water and the pool filtration circuit ready to operate.

Before connecting the mains electricity supply to the Heatstar, the following procedure should be followed :

## **CHECK ELECTRICAL SAFETY**

- Check correct and good Earth connection.
- Check rating and operation of RCD and MCB breakers.

## **START UP POOL WATER FILTRATION PUMP**

Connect mains electricity supply to the pool water filtration pump and leave running until the entire water system is primed and all air has been expelled from the pipe work. This can take several minutes.

It may be necessary to bleed air from high points in the pipe circuit.

Check that there are no leaks within the pool water pipe circuit and that the pressure gauge on the pool water filter is indicating normal pressure.

## **AIR FILTER**

Ensure that the pool hall intake air filter is in place and that it is not obstructed by dust etc.

## **BUILDING DUST**

Do not start the Heatstar if the pool hall is dusty, for this will quickly obstruct the air filter.

## **AIR DUCT WORK**

Ensure that the air duct work is clear from obstructions or water.

If any air or fire dampers are fitted within the duct work or grilles, ensure that these are open.

## **SWITCH ON FUEL BOILER**

Ensure that the fuel boiler and associated circulating pump is ready to function.

If the fuel boiler is controlled via the Heatstar, the boiler may not come on until the Heatstar is switched on and demanding heat.

## **SETTING THE CONTROLS**

Check the controls on the Heatstar are set as listed in 'Initial Control Settings' (these are factory pre-set).

## **ACCESS PANELS**

Ensure that all access panels on the Heatstar are securely fastened in place.

## **SWITCH ON ELECTRICAL MAINS POWER TO HEATSTAR**

On the Heatstar control panel, the 'POWER' amber neon should be lit.

The supply fan will start immediately, the exhaust air fan can start following a short delay.

The air heating and pool water heating neons are likely to come on immediately to indicate that heating is being called for.

The dehumidifier compressor motor will probably not switch on until the humidity level in the pool hall has had the opportunity to build up. This will only happen when the pool water is heated up to near the required temperature.

# **COMMISSIONING THE INSTALLATION**

## **ELECTRICITY**

### CHECK ELECTRICAL PHASE ROTATION :

If the electrical supply to the unit is 3 phase in nature, then the fans should be visually checked to ensure that they are rotating in the correct direction :

- Connect the electricity to the Heatstar, enabling it to run.
- Isolate the electricity to the Heatstar to stop it.
- Remove the access panel under the controls and watch as the fan slows to halt.

If the fan rotation is incorrect, it will be necessary for the electrician to swap over the connections of the mains supply electricity cables until the correct phase orientation is established.

### VOLTAGE SUPPLY :

The electrician should ensure that, with all equipment running, that the voltage supplied to the Heatstar falls in line with the minimum requirements as listed under 'Electrical Specifications'.

## **POOL WATER FLOW**

### FLOW CUT-OUT TEST :

With the Heatstar running, switch off the electrical power supply to the pool water filtration pump.

On the Heatstar control panel, the 'POOL WATER FLOW CUT-OUT' red neon should now be lit.

If there is a head of water above the Heatstar, the flow sensor may require adjustment. Should this be the case, please contact Heatstar for details.

After the test, switch the pool water filtration pump back on and, on the Heatstar control panel, the 'POOL WATER FLOW CUT-OUT' red neon should now be off again.

### CHEMICAL DOSING :

Check that all methods of chemical introduction are carried out after the flow of pool water has been through the Heatstar.

If they are before the Heatstar in the line of flow, then serious damage may occur to the Heatstar.

This includes any slow dissolving tablets of ANY description.

The general chemical balance of the pool water should not exceed the indicated appropriate limits.

## **AIR DUCT WORK**

Check that there is appreciable air flow from all grilles. Check that all air discharge grilles within the pool hall are angled correctly and diverting air onto areas of glazing.

## **BOILER OPERATION**

Ensuring that the boiler is called to operate :

If the fuel boiler is dedicated to the Heatstar then, depending upon how the electrician has chosen to wire the control circuit, the boiler may only switch on automatically when the heating is called for.

With the Heatstar running, on the Heatstar control panel the 'Air Temperature' green neon should be lit calling for air heating. If this is not the case then temporarily increase the control setting temperature until the neon is lit.

This should ensure that the fuel boiler is called to operate.

The boiler water is simply re-circulated through the Heatstar, then back to the boiler.

The boiler water is pumped around this closed circuit by the boiler circulating pump, which will normally be located either close to the boiler or actually inside the boiler.

After a short time, the copper pipe work from the boiler through the Heatstar should become very hot.

Boiler water temperature :

The fuel boiler will invariably have a temperature control dial which governs how hot the boiler water through the Heatstar will be. This should be set to 80°C.

Such a temperature is obviously very hot and is not far short of boiling. Therefore the copper pipe entering the Heatstar should be far too hot to hold for any length of time. If this is not the case, then the boiler is not supplying enough heat to the Heatstar.

### **CONDENSING BOILERS :**

If the fuel boiler is a high efficiency condensing type boiler, then it may be necessary to operate at lower boiler water flow temperatures in order to achieve optimum efficiency, for example 70°C flow / 50°C return.

It must be appreciated that operating at these reduced flow temperatures will directly reduce the heating output ability of the Heatstar. If the intention is to operate a condensing boiler at these temperatures, then it will be necessary to make allowance in the initial selection / design of the project if correct pool hall temperatures are to be maintained at all times.

Boiler water flow speed :

The temperature of the boiler water coming out of the Heatstar should be slightly lower than that going in. This is because the Heatstar has transferred some of the heat to the pool hall air.

If the temperature difference between the 'in' pipe and the 'out' pipe is greater than 11°C, then the rate of boiler water flow through the Heatstar is not fast enough to transfer the optimum amount of heat. With condensing type fuel boilers a 20°C temperature reduction would normally be utilised.

If there is a manual by-pass valve positioned between the 'in' pipe and the 'out' pipe of the boiler pipe circuit, then it is possible that the valve requires to be closed slightly more than it is at present. Do not close such a valve completely as may create problems when the Heatstar no longer requires any heat from the boiler.

Air venting :

If air is present within the boiler water pipe circuit, then this may restrict the flow of heat from the boiler to the Heatstar and cause the problems described above.

There should be air vents positioned at high points around the boiler pipe work circuit and there is an air vent positioned on the top of the air heating coil within the Heatstar.

Caution :        Very hot water may be sprayed from the air vents and due care must be taken to avoid scalding and eye damage.

Once the boiler circuit is confirmed to be operating correctly, the air discharged into the pool hall by the Heatstar should be noticeably warm. Check the boiler pipe circuit for water leaks when both warm and cool.

# ABOUT THE WARMING UP PERIOD

Once the Heatstar is running, the temperatures and humidity within the pool hall will start to be controlled.

## **Air temperature :**

Air can be heated up comparatively quickly and, therefore, the pool hall air can immediately be heated up to the required temperature within a matter of minutes.

If the air heating control is 'ON', the air being discharged into the pool hall will feel notably warm.

If the pool hall structure is well insulated, then the air will tend to hold it's temperature with minimal heating.

## **Pool water temperature :**

To heat up water takes a lot of heat and a lot of time and a typical swimming pool contains many thousand litres of water.

To warm up all the swimming water to the required temperature will normally take from 7-10 days.

If the pool water heating control is 'ON', the temperature of the heated water coming back into the pool will not necessarily feel any warmer.

This is because the pool water will only be increased very slightly in temperature on every re-circulation through the filtration pipe work and the Heatstar and is normal.

Some types of pool shell construction and tiling are sensitive to being heated up too quickly and can be damaged through thermal shock. The warm up time for the pool may require to be manually restricted by the pool owner / operator not to exceed 0.25 C/hr. Contact the pool construction contractor for advice if in doubt.

It should be noted that, if the pool water heating is 'OFF', the pool water will take a similarly long time to cool down.

## **Humidity levels :**

With a new building it will take around two weeks to properly dry the structure and this may temporarily affect the pool hall humidity.

During the warm up period, most of the available heat will be transferred into the pool water at the expense of the air.

If the pool does not have a surface cover in place during the warm up period, then the correct temperature balance will not be sustained during this period and temporarily high humidity levels may be anticipated.

## **Seasoning of wood & plaster :**

With a new pool hall construction, when the Heatstar is first switched on and the pool hall air heated, the humidity levels could become very dry until the pool water reaches normal temperature.

Any wood used within the construction of the pool hall should be suitably treated in consideration of the possible variation in humidity levels and temperatures within the pool hall. Wood is a 'living' material and unsuitably treated wood can be expected to move, shrink or twist.

Likewise, new plaster will initially contain a lot of water and, if dried too quickly, could crack. If in doubt, set the pool hall air temperature at no more than 22C to help slow the drying process.

# ADJUSTMENTS TO THE CONTROL SETTINGS

Within a new installation, it will take around 10-14 days for the system as a whole to balance and stabilise and no control adjustment is advised during this initial period.

If these conditions are acceptable then the controls on the Heatstar will require no further adjustment and the respective settings of the controls should be noted down for future reference.

If you require to operate the system at conditions not yet obtained, then adjust the controls accordingly (refer to 'About The Controls).

It should be noted that the controls should not be moved more than one degree per 24 hours, otherwise the balance of the system may be disturbed.

## CONTROL OF THE POOL WATER CIRCULATION PUMP

The Heatstar should NOT be connected to a time clock.

The pool water circulation pump can be operated via a time clock, as long as :

- The circulation pump is running during the periods when the pool is in use and the surface cover removed.
- If no surface cover is fitted, then the pool circulation pump must run 24 hours per day.
- The circulation pump is running for sufficient time per day to enable effective pool water heating and filtration to take place.

With regard to pool water heating, the minimum run time possible for the pool water circulation pump will be around 8 hours per day.

The Heatstar will automatically sense, via a flow pressure switch, if the pool water circulation pump has switched off and will stop heating the pool water and dehumidifying via refrigeration.

## CONTROL OF THE FUEL BOILER

The fuel boiler supplying heat to the Heatstar should not be governed by any form of time clock control. This also applies to the boiler water circulating pump.

The Heatstar may call for heat from the fuel boiler at any time, day or night, and, if that heat is not available, then control of the pool hall environment will be compromised.

# MAINTENANCE REQUIREMENT

To ensure that the Heatstar is operating to full efficiency, it is recommended that a service is carried out by suitable qualified personnel at six monthly intervals.

It is also recommended that the fuel boiler and pool water filtration plant are also regularly serviced.

In addition to this, it is recommended that the following be periodically checked :

## **POOL HALL AIR FILTER :**

The pool hall air filter is positioned within the air duct spigot connection sucking air from the pool hall.

The purpose of the pool hall air filter is to prevent the finned air heat exchange coils within the Heatstar from becoming blocked.

The type of air filter used is a cardboard box panel containing a filter material. When dirty, the entire air filter is simply disposed off and a new filter fitted.

If the air filters are allowed to become blocked, the airflow to the Heatstar will be restricted, resulting in inefficient running or, in extreme cases, damage to the internal motors.

Shortly after the system is initially started, it may be necessary to renew the air filter. This is because there is likely to be excessive dust in the pool hall during this period.

To remove the filter from the access slot provided, switch off electrical power to the Heatstar, release the two screws holding the slot cover in place and simply pull the filter towards you.

Replacement air filters are available from your supplier.

Please note : The Heatstar should not be operated while building work or tile cutting is still in progress for the dust will quickly block the air filter.

## **FRESH AIR FILTER :**

The heat recuperator module within the Heatstar will serve to partially filter the fresh air as it is drawn into the unit from outside. The plates of the module will help prevent insects and other debris from entering the system.

The plates can be cleaned as follows :

Isolate the electrical supply to the Heatstar and release the screws holding the TOP access panel in place. The plates can then be easily cleaned with a brush and vacuum cleaner.

If more extensive cleaning is necessary, the entire recuperator module can be removed from the Heatstar by releasing the screws holding the fixing brackets.

## **CONDENSATE WATER DRAIN PIPE :**

Any dust etc. which may accumulate on the air heat exchange coils within the Heatstar may be washed down into the condensate drain pipe.

If allowed to build up, such dust may cause a blockage in the pipe, resulting in over flowing of the condensate water collection tray within the Heatstar.

Therefore the pipe should be periodically inspected to ensure that it is clear.

# FROST DAMAGE PREVENTION

The Heatstar obviously incorporates water fed heating coils and, if exposed to freezing temperatures, the water contained within the coils would be prone to frost. The resulting damage would be extensive and costly to repair.

Even before initial installation, the Heatstar should always be protected from frost during storage, for the unit will invariably contain residual water from the testing procedures applied.

If the pool is not in use at any time during the winter months and the heating system shut down, the following procedures should protect the Heatstar from frost damage :

## ELECTRICS :

Isolate the mains electricity supply to Heatstar and all other associated equipment.

Remove the main access panel on the Heatstar and spray the electrics with a water repellent oil. Replace the access panel.

## POOL WATER :

Disconnect and drain the pool water circulation pipe work circuit. Consider where such a large quantity of water will go!

Flush out, using a hose, the pool water inlet and outlet connections on the Heatstar with FRESH water and drain again.

## BOILER WATER :

The boiler water circuit can remain un-drained but it must be confirmed that the an appropriate anti-freeze / anti-corrosion agent has been added to the boiler water.

## STARTING UP THE SYSTEM :

Follow the procedures listed in 'Putting The Unit Into Commission'.

Please note : Frost damage is not covered by the manufacturers warranty.

# CORROSION DAMAGE PREVENTION

The Heatstar incorporates metal heating coils which come into direct contact with the pool water as it passes through the unit.

There are normally two separate heating coils :-

The first is linked to the dehumidification heat pump circuit.

The second (Super Plus versions only) is linked to the fuel boiler water pipe work.

All metals can be damaged through corrosion if exposed to pool water with an aggressive and incorrect chemical composition.

In the case of the Heatstar, if the first heating coil is damaged, then pool water may enter and contaminate the dehumidification refrigeration system and repair costs can be very expensive indeed.

It is obviously usual to continually add potentially corrosive chemicals, such as chlorine and acid, to the pool water in order to maintain a minimum standard of water quality.

However, the metal alloys used within the Heatstar are selected due to their high durability and, if a correct and appropriate chemical balance is maintained within the pool water, and the method of chemical introduction is appropriate, then the Heatstar will be protected from such corrosion damage.

The pool owner or operator must ensure that the chemical balance of the pool water is correct at all times. Corrosion damage to the Heatstar, of any description, is not covered under the manufacturers warranty.

The most basic test kit would provide indication of the Free Chlorine level, pH value, Total Dissolved Solids (TDS) level, and Total alkalinity level.

Although these are the most important aspects to monitor, the pool water composition may contain many more chemicals and substances which could be causing difficulties and, if corrosion damage problems occur and the cause is not clear, often an extensive laboratory test is necessary followed by extensive dilution of the pool with fresh water.

The following precautions will assist in preventing corrosion damage :-

## **CHEMICAL INTRODUCTION :**

All purification devices and chemical injection systems must be fitted **DOWN STREAM** of the Heatstar.

This includes the practice of dosing slow dissolving tablets via the skimmer basket, which can result in concentrated corrosive liquids passing over vulnerable metal components within the Heatstar. This relates to any slow dissolving tablets of ANY description, whether chlorine based or not.

Please note that the installation and usage instructions for the chemical dosing equipment often recommend that the chemical is introduced before the pool water sand filter. This should **NOT** be done unless the Heatstar is installed on a completely different pipe circuit.

If the chemicals are introduced down stream of the Heatstar but, if the filtration pump stops or the filtration system is drained down, the chemicals can be drawn back through the Heatstar, then a non-return valve must be fitted in the pool water pipe work.

## **pH Value :**

The degree of acidity or alkalinity of water is measured in terms of its pH value. A pH of 7 is neutral; a pH falling below 7 indicates an increasing degree of acidity, and a pH rising above 7 indicates an increasing degree of alkalinity.

The correct pH value is necessary normally to ensure effective disinfection and to prevent corrosion or scale formation.

The pH level **MUST** be maintained between 7.2 and 7.8.



**ALKALINITY :**

The correct alkalinity must be maintained to buffer the water against pH fluctuations and to prevent damage through corrosion or scale formation.

The total alkalinity level **MUST** be maintained between 80 - 160 mg/L.

T.D.S. (Total Dissolved Solids) :

The chemicals which are introduced into the pool water leave by-products which can build up over a period of time, such as chlorides and sulphates.

T.D.S. can only be reduced by dilution with fresh water. Dilution occurs every time the pool filter is back washed.

The T.D.S. level **MUST** not exceed 1500 mg/L.

**DISINFECTANT LEVEL :**

Free chlorine is most important in relation to swimming pool disinfection. In chlorine treated pools a free chlorine residual of at least 1mg/L should be maintained at all times. The free chlorine level **MUST** be maintained between 1 and 3 mg/L.

If bromine is used, the level must be maintained between 2 and 3 mg/L.

If ozone is used, the level must be maintained between 0.8 and 1.0 mg/L.

If baquacil is used, the level must be maintained between 25 and 50 mg/L.

**SALT PURIFICATION SYSTEMS :**

The Heatstar is not warranted for use in conjunction with any form of salt chlorination or electrolytic system due to potential concerns of an enhanced risk of corrosion. The warranty exclusion relates only to corrosion damage.

**ELECTROLYSIS :**

Electrolysis can be caused by a bad or non-existent earth connection. Faulty electrical insulation on any apparatus connected in the system will allow electricity to run to earth via the metal components in contact with the swimming pool water.

This will create a cathode / anode effect and may lead to metal components being damaged.

**INCORRECT WINTERISATION :**

If the Heatstar and filtration system are not required to be in operation for a period of time and are not flushed with fresh water, then the conditions of the stagnant pool water retained within the system may prove damaging as the water evaporates to leave increased concentration of corrosive chemicals.

The essential requirement is that the water should be properly balanced - that it is neither corrosive nor scale forming when measured by the Langelier Saturation Index.

As the condition of the pool water and the design of the disinfection system are obviously beyond the control of the manufacturers, no warranty claim can be accepted if the product has been damaged in any way due to any form of corrosion.

Please look after your Heatstar.

# FAULT FINDING

If a problem of any description is suspected with the Heatstar, firstly ensure the following;

CAUTION - isolate the Heatstar electrically before removing any access panel.

## ELECTRICAL PROBLEMS

### **MAINS ELECTRICITY :**

Ensure that the 'POWER' amber neon on the Heatstar is lit.

If it is not, then there is no electricity supply to the Heatstar - check that :

- the RCD and MCB and any other switch controlling the electricity.
- any external time clock is switched on at all times.
- the neutral wire is properly connected.

If the 'POWER' amber neon is off and other neons on the Heatstar are lit, this indicates that the 'POWER' neon bulb is faulty.

If the RCD / MCB supplying electricity to the Heatstar keeps tripping - check :

With the Heatstar disconnected from the mains electricity supply, including the neutral, the RCD does not continue to trip. This indicates that the electrical fault is not within the Heatstar.

If the RCD or MCB supplying the Heatstar cannot be re-set or trips as soon as electricity is connected to the Heatstar. This indicates that there may be an electrical short within the Heatstar.

It could also indicate that there is an accumulation of earth leakage of between several electric motors supplied by the same RCD. Switch off all other motors and try to operate the Heatstar on it's own.

Ensure that the electricity supply to the Heatstar is isolated and remove the access panel to check for the presence of water within the unit which may be causing the short. If no water is present, then the problem is likely to relate to the main supply fan or exhaust fan power controller. Please contact Heatstar for further advice.

If the RCD re-sets initially, enabling the Heatstar to run, and then trips after a few minutes, this indicates a possible problem with the refrigeration compressor motor circuit. Please contact Heatstar for further advice.

### **AIR FLOW PROBLEMS :**

If the air flow into the pool hall appears reduced, ensure that :

There is no restriction to the air flow to or from the Heatstar - check that :

- any air filters are clean.
- the intake coils to the Heatstar are clean.
- the pool air temperature is in excess of 19°C.
- all access panels on the Heatstar are securely in place.
- there is no water present in any under floor air ducting.
- any dampers on the air grilles are open.
- That any fire dampers within the air duct work are open.
- That the internal plate recuperator is clean.

If there is no appreciable air flow into the pool hall or the air flow keeps being interrupted and the 'POWER' amber neon on the Heatstar is lit, ensure that :

- The internal fan thermal protection cut-out control has not activated.  
Switch the Heatstar off and contact Heatstar for information on possible causes.

### **HIGH HUMIDITY IN POOL HALL :**

If the humidity level within the pool hall appears abnormally high, i.e. above 70% RH, check that :

- The pool hall air temperature is warm enough i.e. above 28°C if the pool is uncovered.
- The 'DEHUMIDIFICATION' green neon on the Heatstar control panel is lit.  
If it is not, then change the humidity control setting to request a lower humidity level.

If, the neon is still not lit, check that :

- The 'POOL WATER FLOW CUT-OUT' is not lit, see below.

If the above is the case, then contact Heatstar for advice.

If the 'DEHUMIDIFICATION' green neon is lit, check that :

- There is not water present within any under floor air distribution duct work.
- Isolate the Heatstar from the electricity supply, remove the access panel and ensure that there is no water present within the Heatstar.
- The pool hall air temperature is above the pool water temperature when the pool is uncovered.

Please note that, during cold weather, some condensation on double glazing may be anticipated and is normal.

### **POOL WATER FLOW CUT-OUT :**

If this red neon is lit then there is insufficient flow of pool water through the Heatstar. If this is lit, check that :

- The pool water filtration pump is running.
- Any valves controlling flow through the Heatstar are in the correct position.
- That the pool water filter pressure gauge is reading less than 16 PSI.
- Ensure that the pool water filter does not require back washing.

When sufficient flow is restored, the Heatstar will automatically re-set and function normally.

### **WATER LEAK FROM HEATSTAR :**

The Heatstar will normally contain water from the pool, water from the boiler and condensate from the dehumidification process.

If a water leak is suspected within the Heatstar, check that :

- The water condensate drain pipe is not blocked, causing the internal collection tray to over flow.
- That there is a U-bend trap on the water condensate drain pipe.

If an internal pool water or boiler water leak is suspected, isolate the Heatstar electrically and remove the access panel below the controls :

#### **Boiler water :**

To test the internal boiler pipe work, with the boiler water circulating pump running :

- Open all internal motorised heating valves manually using the levers on the ends of the valves. This will allow boiler water to flow through all of the boiler pipe work.
- Check the internal air vent on the L.T.H.W. air heating coil has not been left open.
- Observe for any other signs of moisture.

## **Pool water :**

To test the internal pool water pipe work, with the pool water circulating pump running :

- Observe for any signs of moisture.

If a leak is apparent within the Heatstar, please contact Heatstar for advice.

If installed correctly, it should be possible to isolate the Heatstar from the pool water circuit using the by-pass valves, enabling the filtration circuit to function normally.

With a new installation it should be noted that, during commissioning, it may be necessary to tighten the internal connection nuts on the heating valves and the internal connection unions on the pool water heat exchanger. This is due to normal expansion / contraction as the operating temperatures rise.

## **AIR TEMPERATURE PROBLEMS :**

The heating of the pool hall air is a very simple process :

The heated boiler water is circulated through a 'car radiator' type coil within the Heatstar. The pool hall air is blown through this coil, picking up heat as it does so.

The flow of hot boiler water into the heating coil is controlled by an electric valve:

When the valve is closed, no hot water from the boiler is allowed to enter the air heating coil, therefore air heating will be 'off'.

When the valve is electrically opened, hot water from the boiler is allowed to enter the air heating coil, therefore air heating will be 'on'.

The valve is electrically opened by the 'AIR TEMPERATURE' control which is a THERMOSTAT which measures the pool hall air temperature. If the pool hall air temperature is colder than the setting on the thermostat, then the electric heating valve will be switched 'on' and it will be motored open.

For 'Super Elec' or 'Super Plus Elec' versions, see dedicated notes on all electric heating models.

When the 'AIR TEMPERATURE' control believes that air heating is required, the corresponding green neon will be lit.

### Pool hall air temperature too high :

If the pool hall air temperature is too high, check that :

- The green neon under the AIR TEMPERATURE control is not lit.  
If it is, reduce the control setting temperature (both F1 and F2 settings)  
If the set temperature is less than the actual display temperature and the green neon remains lit, then this may indicate a faulty thermostat. Contact Heatstar for advice.
- That any external electric valve is opening / closing properly.
- That the internal motorised valves are not stuck open.

Please note :

The normal pool hall air temperature will feel very warm and tropical in nature (30°C).

The pool hall air temperature may not notably decrease during the 'set back' period. This is quite normal and indicates good building structure insulation.

### Pool hall air temperature too low :

If the pool hall air temperature is too low, check that :

- If the DEHUMIDIFICATION green neon is lit due to excess pool hall air humidity, then the Heatstar is attempting to reduce the pool hall humidity (see 'ABOUT THE CONTROLS').
- The green neon under the AIR TEMPERATURE control is lit.  
If it is not, increase the control setting temperature (both F1 and F2 settings).  
If the control setting temperatures are set high and the green neon remains off, then this may indicate a faulty thermostat. Contact Heatstar for advice.
- That both the copper pipes coming from the fuel boiler are too hot to touch, (see 'CHECKING THE INSTALLATION SERVICES).

### **POOL WATER TEMPERATURE PROBLEMS :**

The heating of the pool hall air is a very simple process :

The heated boiler water is circulated through a coil within a heat exchanger. The pool water is passed around this coil, picking up heat as it does so.

The flow of hot boiler water into the heating coil is controlled by an electric valve:

When the valve is closed, no hot water from the boiler is allowed to enter the heating coil, therefore pool water heating will be 'off'.

When the valve is motored open, hot water from the boiler is allowed to enter the heating coil, therefore pool water heating will be 'on'.

The valve is 'motored open' by the WATER TEMPERATURE CONTROL which is a THERMOSTAT which measures the pool water temperature. If the pool water temperature is colder than the setting on the thermostat, then the electric heating valve will be switched 'on' and it will be motored open.

When the WATER TEMPERATURE CONTROL believes that pool water heating is required, the corresponding green neon will be lit.

### Pool water temperature too high :

If the pool water temperature is too high, check that :

- The green neon under the WATER TEMPERATURE CONTROL is not lit.  
If it is, reduce the control setting temperature.  
If the control setting temperature is set very low and the green neon remains lit, then this may indicate a faulty thermostat. Contact Heatstar for advice.
- That any external electric valve is opening / closing properly.
- That the internal motorised valves are not stuck open.

The pool water circulation pumps transfer the majority of their electric motor power consumption directly into the pool water and this can lead to over heating.

### Pool water temperature too low :

If the pool water temperature is too low, check that :

- The 'POOL WATER CUT-OUT' red neon is not lit.  
If it is see 'POOL WATER CUT-OUT' above.
- The green neon under the WATER TEMPERATURE CONTROL is lit.  
If it is not, increase the control setting temperature.  
If the control setting temperature is set very high and the green neon remains off, then this may indicate a faulty thermostat. Contact Heatstar for advice.
- That both the copper pipes coming from the fuel boiler are too hot to touch, (see 'CHECKING THE INSTALLATION SERVICES).

Please note :

To heat up water takes a lot of heat and a lot of time and a typical swimming pool contains many thousand litres of water.

The temperature of the heated pool water coming back into the pool will not necessarily feel any warmer. This is because the pool water will only be increased very slightly in temperature on every re-circulation through the filtration pipe work and the Heatstar and is quite normal.

**ALL ELECTRIC HEATING MODELS : (Super Elec & Super Plus Elec only)**

These versions do not require any connection to a fuel boiler and heat using direct electric resistance elements.

Each heating coil has a safety over-heat cut-out. In the event that a cut-out has occurred, the cut-out is re-set simply by switching the mains electricity to the Heatstar off and then back on again.

If the cut-out re-occurs, the cause of the cut-out requires to be investigated and resolved. Failure to do so represents a fire hazard. Contact Heatstar for advice.

# HEATSTAR EXTENDED WARRANTIES

In the UK the Heatstar is supported by a full parts and labour warranty which initially runs for one year from the original supply date. When this initial period expires, continuing extended warranty cover is then available at an additional premium.

To ensure that the equipment continues to operate efficiently and reliably, routine maintenance is recommended every six months and, in this respect, all Heatstar extended warranty options also include a routine maintenance visit twice per year.

There are three different levels of cover on offer :

**GOLD** : Full Extended Warranty.

With GOLD cover, the equipment is routinely serviced twice per year. In addition, should any repair work normally covered by the terms of warranty be necessary, the unit would be repaired without charge for parts, labour or attendance.

**SILVER** : Maintenance Cover.

With Silver cover, the equipment is routinely serviced twice per year. In addition, should any repair work be necessary, the client would only be charged for the cost of any component parts used with no charge being made for labour or attendance.

**BRONZE** : Service Cover.

With Bronze cover, the equipment is routinely serviced twice per year. However, should any repair work be necessary, the client would be charged for the cost of any parts used and also charged for labour and attendance.

The service and maintenance contracts can be taken out at any time, subject to the condition of the unit, and are renewable annually.

If the equipment is still covered under the manufacturers warranty, then BRONZE maintenance cover can still be taken out to supplement the warranty with servicing.

With Gold & Silver only repair work normally covered under the manufacturers warranty will be included.

The costs of the various levels of cover vary depending on the unit model and location. Full details are available from Heatstar on request.

## DISPOSAL OF REDUNDANT PRODUCT

The refrigeration circuit within the Heatstar incorporates refrigerant and oil. When the time comes to renew the Heatstar, a refrigeration company should be employed to recover any remaining refrigerant and to safely dispose of the oil.

# EC DECLARATION OF CONFORMITY

Manufacturer : HS EUROPE LTD

Address : Manners View  
Dodnor Park  
Newport  
Isle of Wight.  
PO30 5FA  
ENGLAND

Declares that : Under our sole responsibility :

The Product : Swimming Pool Environmental control unit.

Model : Heatstar Phoenix XF

Conforms to :	Directive 89/336/EEC :	EMC
	Directive 73/23/EEC :	Low voltage
	Directive 98/37/EEC :	Safety of machines
	Standard EN 292 :	Machine safety
	Standard EN 60335-2-40 :	Electric dehumidifiers
	Standard EN 50081-1-EMC :	Generic Emission
	Standard EN 50082-1-EMC :	Generic Immunity

May 2008

P. SCOTT  
Technical Director