

Hydrotuf Pumps



Power performance pump



Hydrotuf is equipped with an innovative lid and lock ring for easy access to a large capacity 2.25L strainer basket, minimising pump maintenance.

Hydrotuf is ideal for large domestic swimming pools with ancillary systems such as heating, in-floor cleaning, vacuum cleaning, fountains and swim jets.

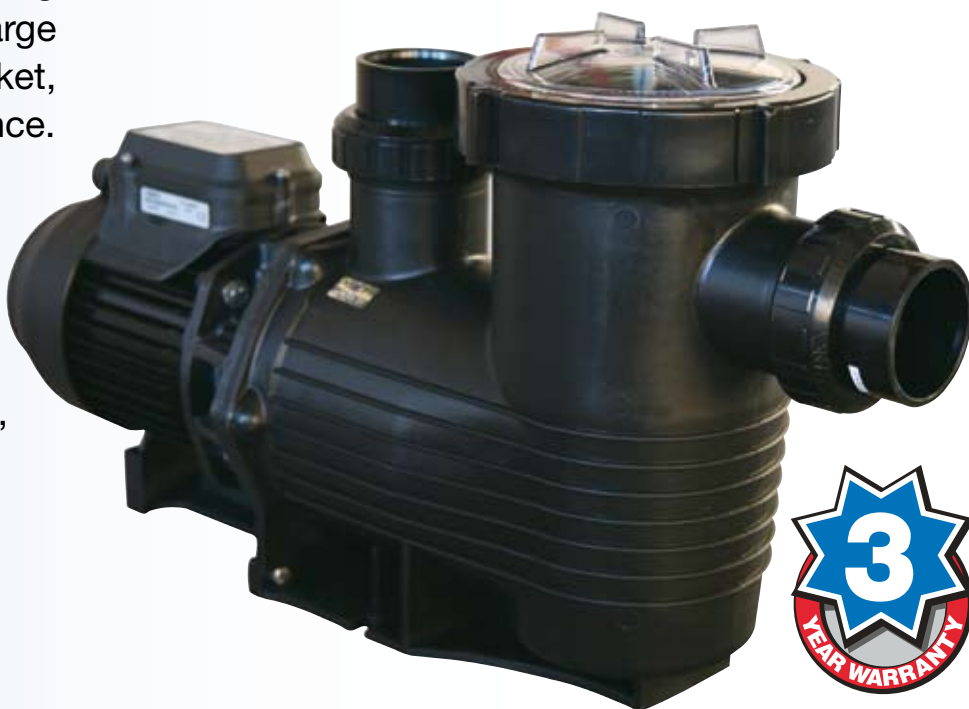

Efficient Impeller and Diffuser Design

The pump's impeller and diffuser design maximizes the hydraulic output of the pump while minimising turbulence. The pump's efficient hydraulic performance shortens run times and reduces energy consumption leading to lower operating cost.

Engineered Durability

The pump body is manufactured utilising state of the art engineering plastic moulding with a single piece strainer pot and volute for extra strength.

- Clear pump lid - enables easy identification of cleaning requirements
- 50mm quick connect barrel unions for UPVC pipe
- High grade carbon/graphite mechanical seal with 316 stainless steel spring assembly
- High performance motor:
 - IP55 rating
 - Fan cooled
 - Thermal overload protection
 - Motor shaft 431 grade stainless steel
- Stable support base
- Impeller / diffuser – glass filled Noryl
- UV stabilised and corrosion resistant
- Extra large 2.25lt strainer basket – captures debris and protects the pump's impeller
- Strong single piece glass filled thermoplastic pump body

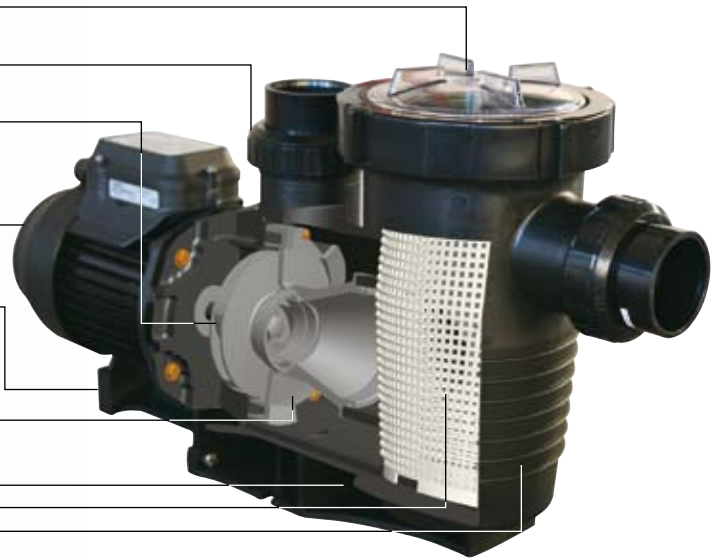

Technical Specifications

Model	Flow rate (lpm)		Nominal Power (hp)	Motor input (kW)	Amps	Weight (kg)	Total Length	Motor Frame	Pump Rating
	8m	10m							
Hydrotuf 100	225	190	1.00	0.86	4.0	9.60	651	71	IPX5
Hydrotuf 125	280	240	1.25	0.95	4.0	9.60	651	71	IPX5
Hydrotuf 150	325	285	1.50	1.10	4.7	12.60	691	80	IPX5
Hydrotuf 200	400	355	2.00	1.50	6.8	12.60	691	80	IPX5

Phase	Volts	Cycle	RPM
1	220- 240	50	2860

Hydrotuf Pumps Performance Curves

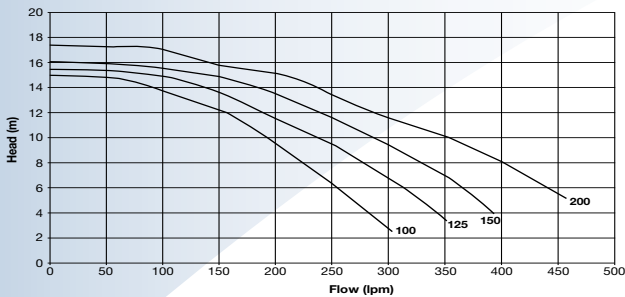

Hydrotuf Pumps Noise

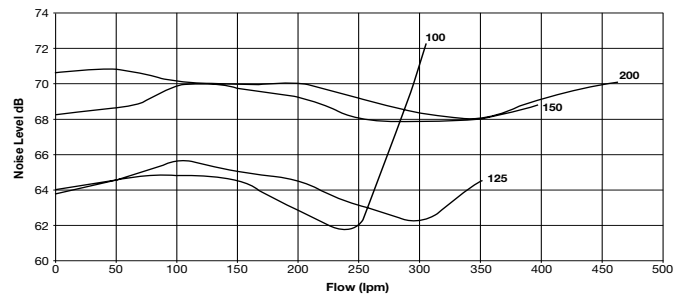

Dimensions

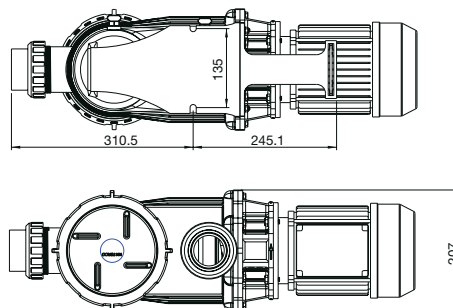
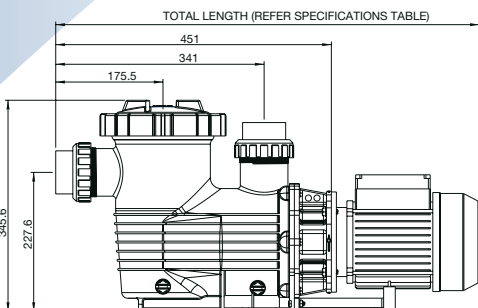

Warranty

Waterco pumps are covered by a 3 year warranty on the pump wet end, 2 year warranty on the pump motor and 1 year warranty on the mechanical seal. Commercial installations are covered by a 1 year warranty for all components.

OFFICES - AUSTRALIA

NSW - Sydney (Head Office)
Tel: +61 2 9898 8600
QLD - Brisbane
Tel: +61 7 3299 9900
VIC/TAS - Melbourne
Tel: +61 3 9764 1211
WA - Perth
Tel: +61 8 9273 1900
SA/NT - Adelaide
Tel: +61 8 8244 6000
ACT Distribution
Tel: +61 2 6280 6476

OFFICES - OVERSEAS

Waterco (Europe) Limited
Sittingbourne, Kent. UK
Tel: +44 (0) 1795 521 733
Waterco (USA) Inc
Augusta, Georgia, USA
Tel: +1 706 793 7291
Waterco Canada
St Hyacinthe, Quebec, Canada
Tel: +1 450 796 1421
Waterco (NZ) Limited
Auckland, New Zealand
Tel: +64 9 525 7570

Waterco (C) Limited
Guangzhou, China
Tel: +86 20 3222 2180

Waterco (Far East) Sdn Bhd
Selangor, Malaysia
Tel: +60 3 6145 6000

PT Waterco Indonesia
Jakarta, Indonesia
Tel: +62 21 4585 1481

Waterco Singapore Intl Pte Ltd
Marine Parade Centre,
Singapore
Tel: +65 6344 2378

DISTRIBUTED BY:

WATERCO
Water, the liquid of life

